

APPROVAL STAMP OF N.M.M.C.

या कार्यालयीने मंडळाच्या वतीने प्रत्यक्ष हस्ताक्षर
मार्फत (१९/०३/२०१८) १३०/१२८९१
मधील सर्व कांतीत अधिकार प्राप्त झाले आहे.

हुल्लात (अनुमोदनासाठी) निवासी
कार्यालयीने मंडळाच्या वतीने मंडळाच्या

मंडळाच्या वतीने
मंडळाच्या वतीने

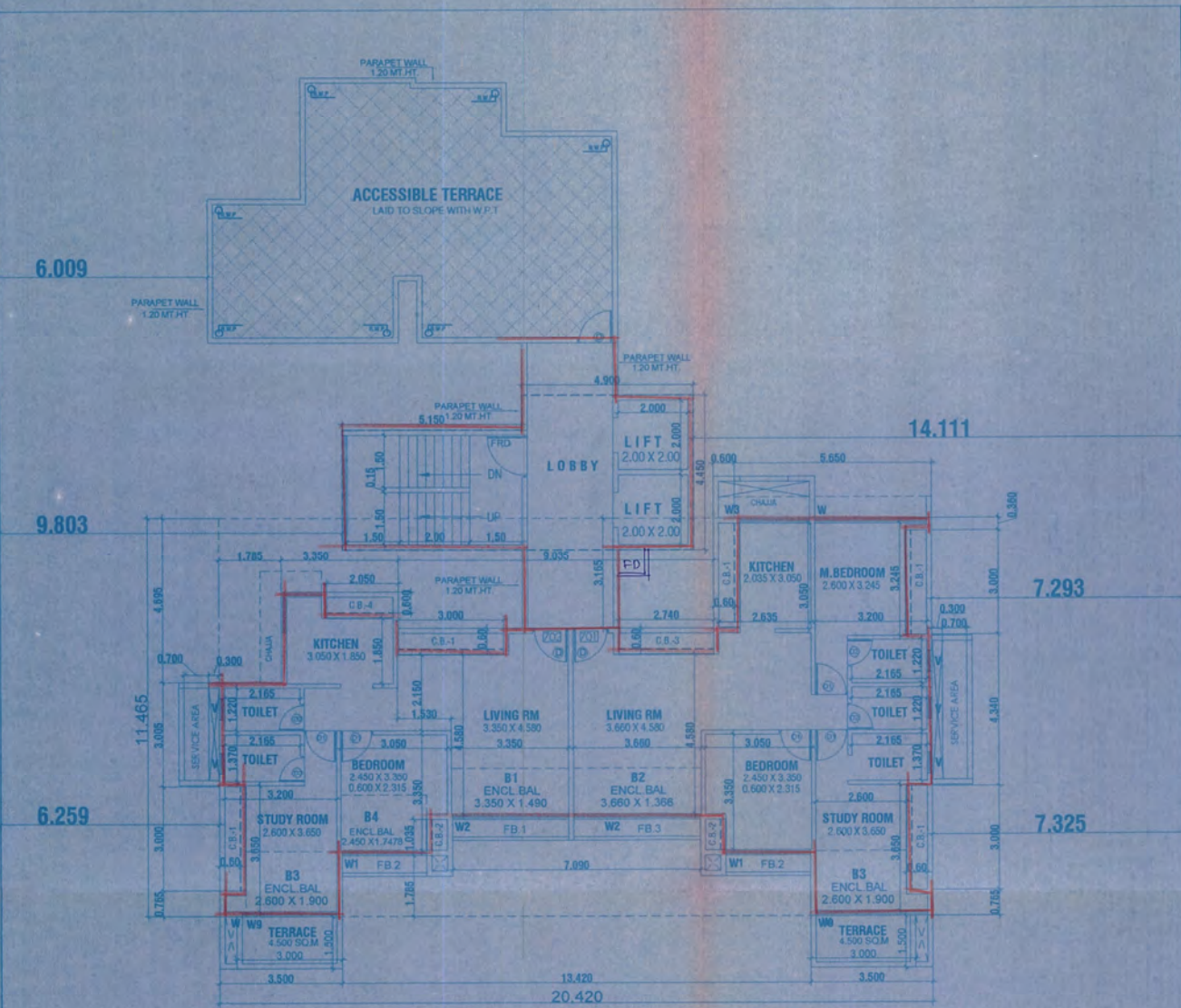

6TH FLOOR PLAN

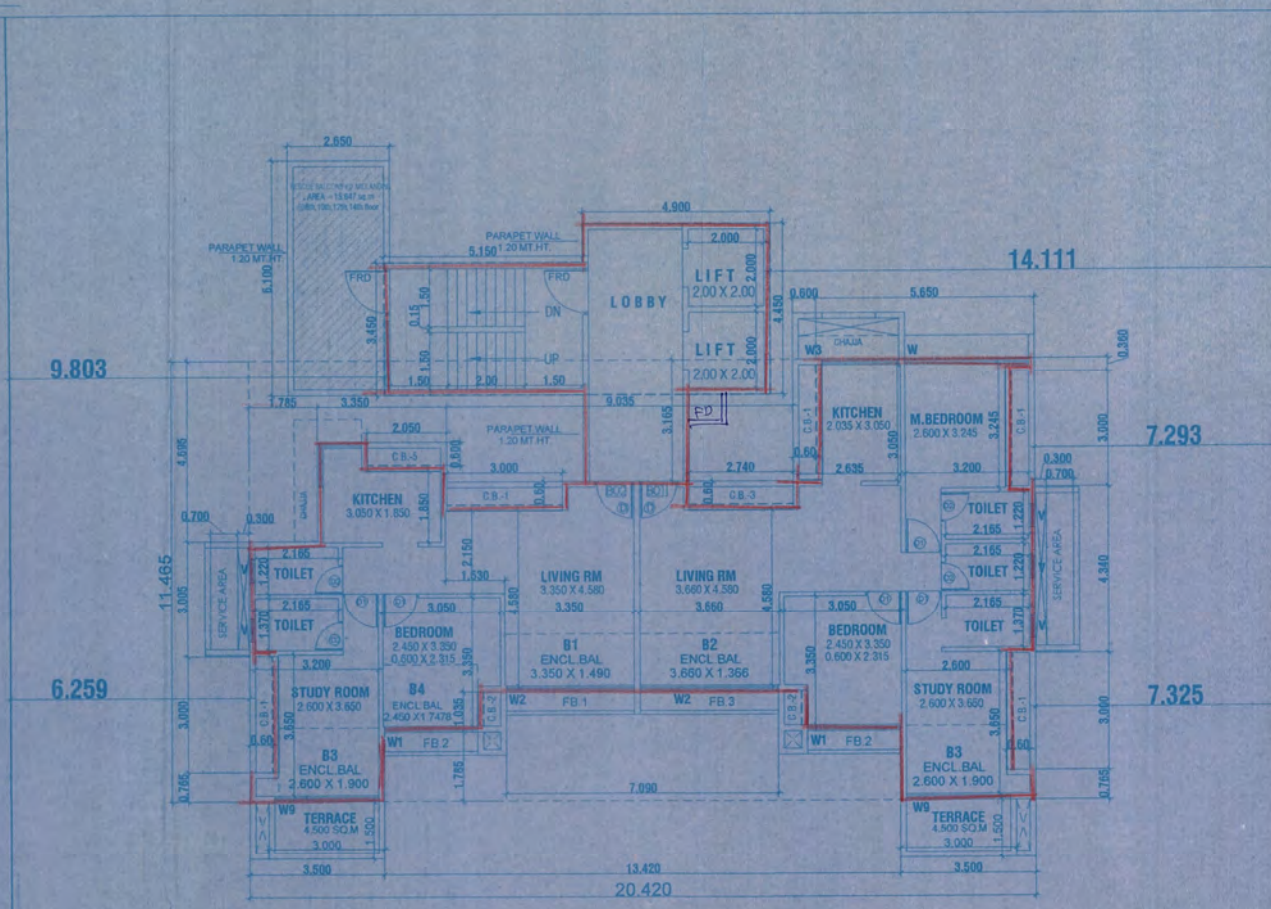

8TH, 10TH, 12TH, 14TH FLOOR PLAN

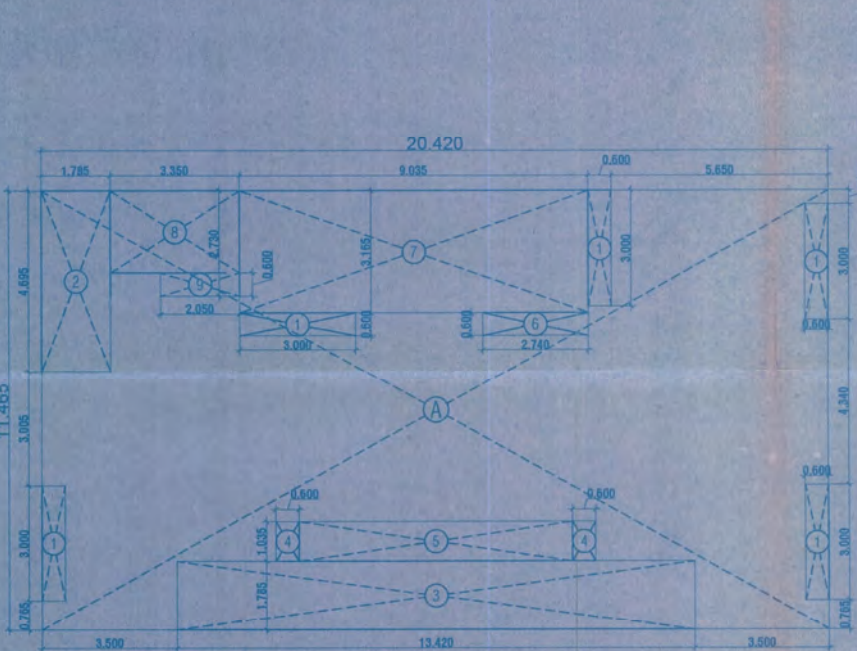

AREA DIAGRAM OF 7TH TO 14TH FLOOR

BUILT-UP AREA STATEMENT : 6TH TO 14TH FLOOR AREA ADDITIONS :-

A. 20.420 X 11.465 =	234.115 SQ.M
C. STAIRCASE AREA =	39.572 SQ.M
TOTAL ADDITIONS =	273.687 SQ.M

STANDARD DEDUCTIONS :-

1. 3.000 X 0.600 X 5 =	9.000 SQ.M
2. 1.785 X 4.695 =	8.381 SQ.M
3. 13.420 X 1.785 =	23.955 SQ.M
4. 0.600 X 1.035 X 2 =	1.242 SQ.M
5. 7.090 X 1.035 =	7.338 SQ.M
6. 2.740 X 0.600 =	1.644 SQ.M
7. 9.035 X 3.165 =	28.595 SQ.M
8. 3.350 X 2.130 =	7.135 SQ.M
9. 2.050 X 0.600 =	1.230 SQ.M
TOTAL DEDUCTIONS =	88.520 SQ.M

GROSS AREA = 273.687 - 88.520 = 185.167 SQ.M
PERMI. BALC. 15% = 185.167 x 15/100 = 24.152 SQ.M

PROPOSED BALCONY :-

B1. 3.350 X 1.490 X 1 =	4.991 SQ.M
B2. 3.660 X 1.366 X 1 =	4.989 SQ.M
B3. 2.600 X 1.900 X 2 =	9.880 SQ.M
B4. 2.450 X 1.7478 X 1 =	4.282 SQ.M
TOTAL BALCONY AREA =	24.152 SQ.M

STAIRCASE & LIFT AREA

S1. 5.150 X 3.450 X 1 =	17.768 SQ.M
S2. 4.900 X 4.450 X 1 =	21.805 SQ.M
TOTAL STAIRCASE =	39.572 SQ.M

PROPOSED NET B.U.A. ON 7TH TO 14TH FLOOR (GROSS AREA) - (BALCONY AREA + STAIR AREA)
(185.167) - (24.152 + 39.572) = 121.443 SQ.M

PROPO. NET B.U.A. ON 7TH TO 14TH FLOOR = 121.443 SQ.M
121.443 X 9 = 1092.987 SQ.M

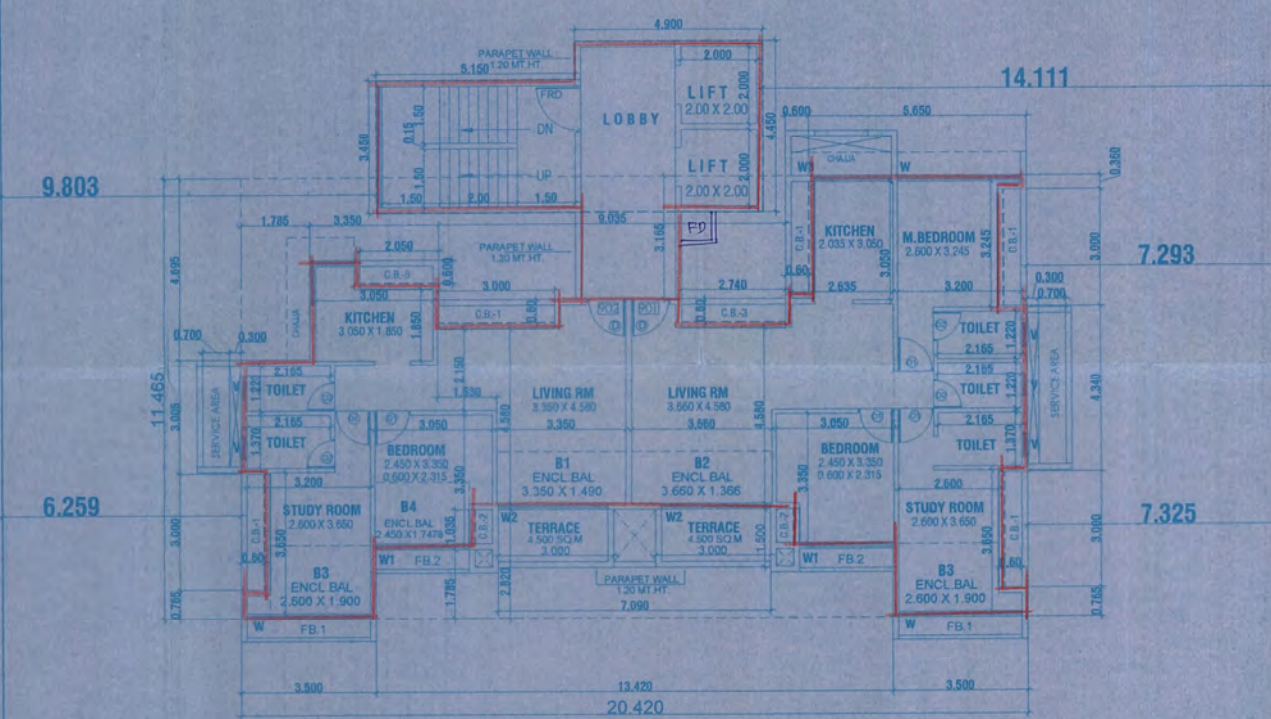

7TH, 9TH, 11TH, 13TH FLOOR PLAN

DESCRIPTION OF PROPOSAL

M/s SEAWOOD HEIGHTS CO-OP. HOUSING SOCIETY LTD.
PROPOSED RESIDENTIAL BUILDING ON
PLOT NO. 03, SECTOR - 42, NERUL
NAVI MUMBAI.

NAME & SIGNATURE OF OWNER

For Seawood Heights Co-op. Hsg. Society Ltd.
14050133008
M/s SEAWOOD HEIGHTS CO-OP.
HOUSING SOCIETY LTD.

NAME & SIGNATURE OF ARCHITECT

SATISH V. AHUJA

NAME & ADDRESS OF ARCHITECT

ARCHITECT
SATISH V. AHUJA

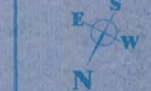

SCALE :- 1:100
DATE :- 15/02/2011
DRN. BY :- NITESH
CHKD. BY :- S.V. AHUJA
DRG. No :- 03

2-C-WING ASHIANA PLOT NO. 15,
SECTOR-17, VASHI, NAVI MUMBAI
PHONE 27898844, 9821196129