

CC (1)

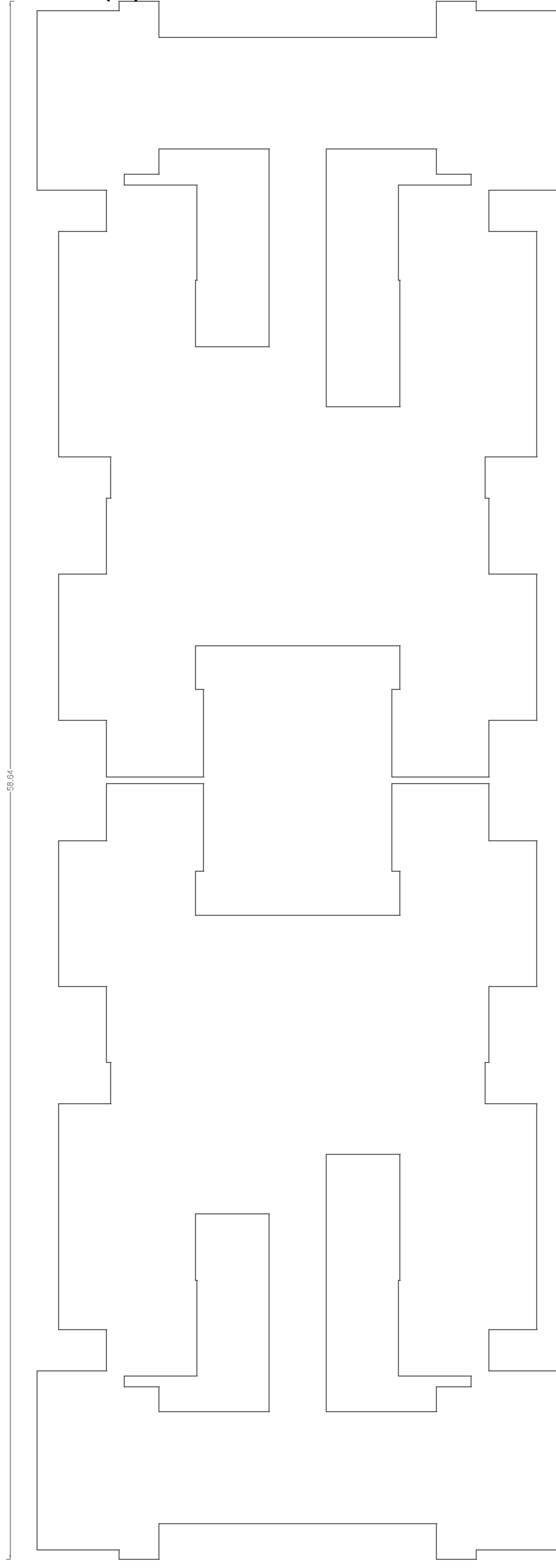

Poly Coverage	Area
	806.39

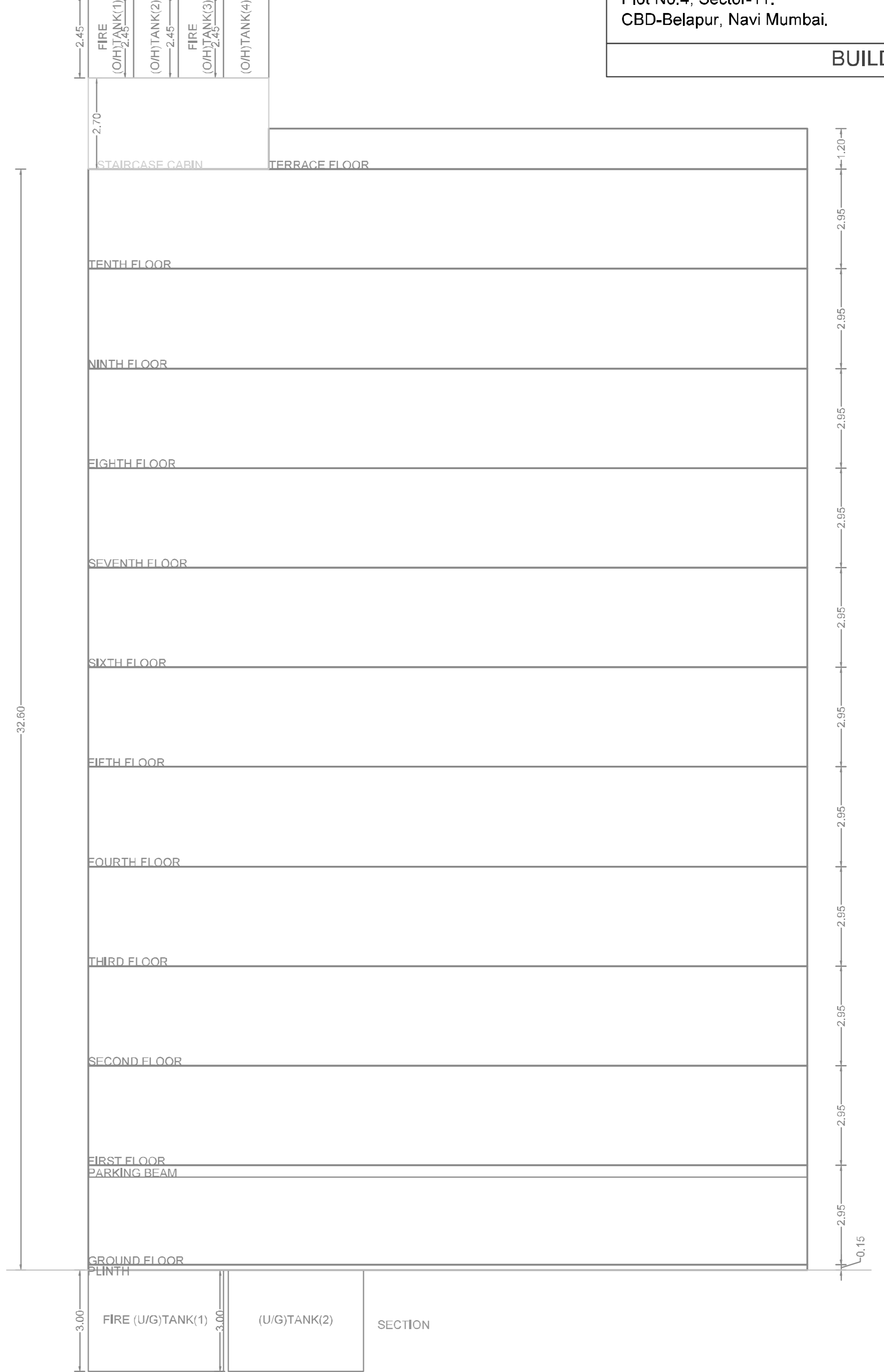
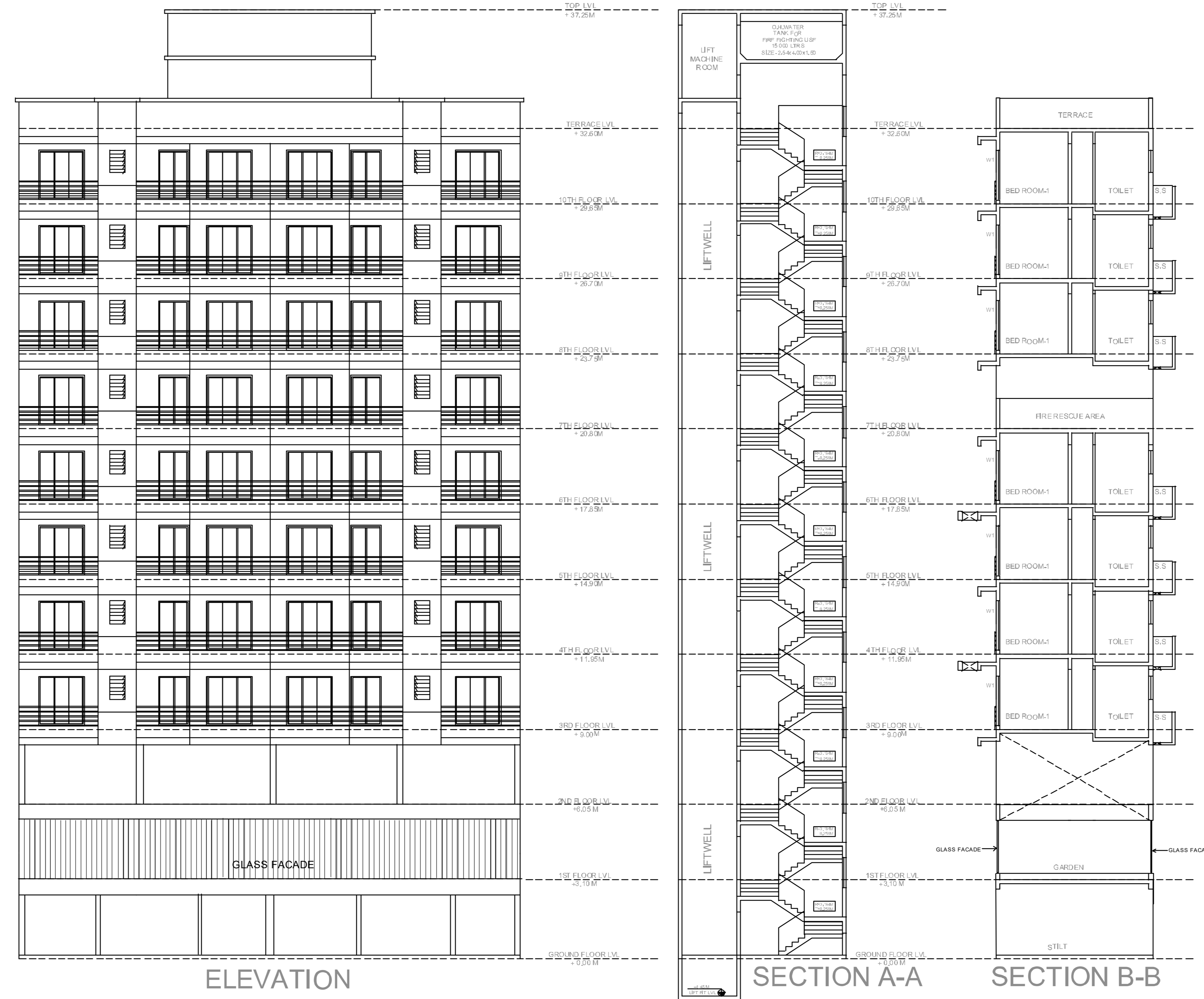

SEAL OF APPROVAL

APPROVED SUBJECT TO THE CONDITION MENTIONED IN the office letter

No. CIDCO/BP-16301/TPO(NM&K)2019/3998
 Scrutiny Date 07-03-2019

APPROVED SUBJECT TO THE CONDITION MENTIONED IN This Office Letter
 No. CIDCO/BP-16301/TPO(NM & K)2019/3998
 dt. 15 Feb 2019

Document certified by PATIL MITHLESH JANKARSHAN
 Name: PATIL MITHLESH JANKARSHAN
 Designation: Associate Planner
 Organization: CIDCO LIMITED
 Date: 15-Feb-2019 19:01:12

Sr.Planner/Asso.Planner(BP)
 CIDCO of Maharashtra Ltd.
 Rajghat Bhavan, 4th Floor,
 Plot No.4, Sector-11,
 CBD-Belapur, Navi Mumbai.

BUILDING: CC (1)

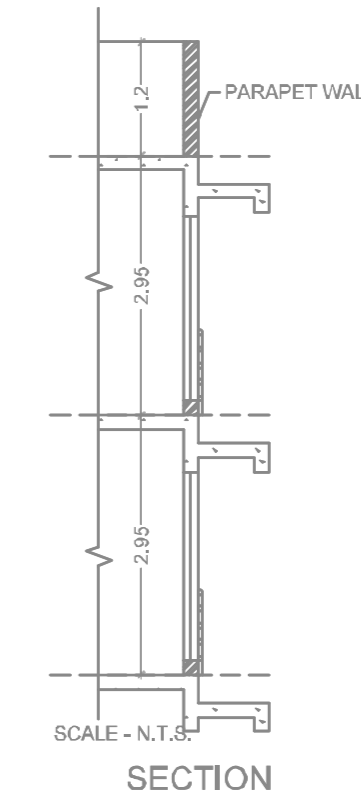
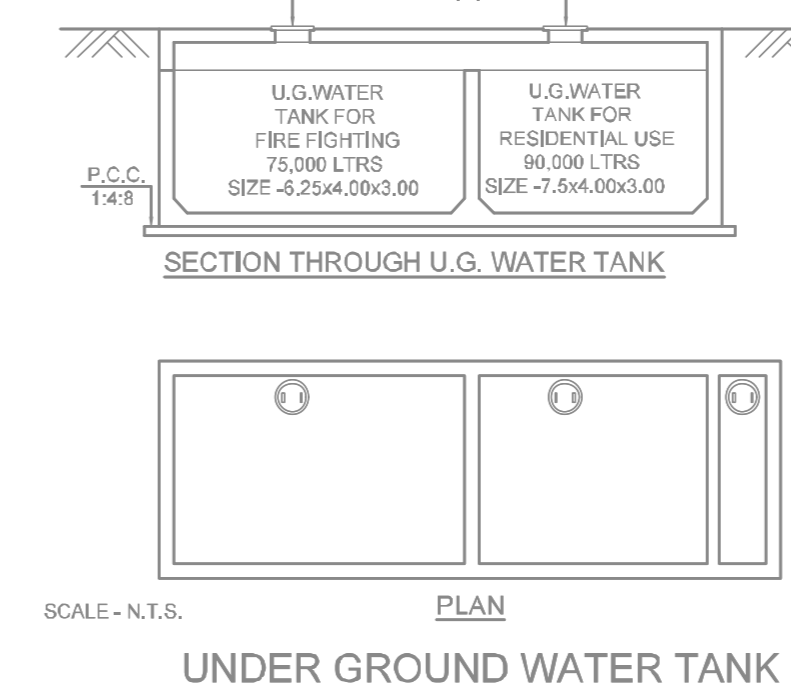
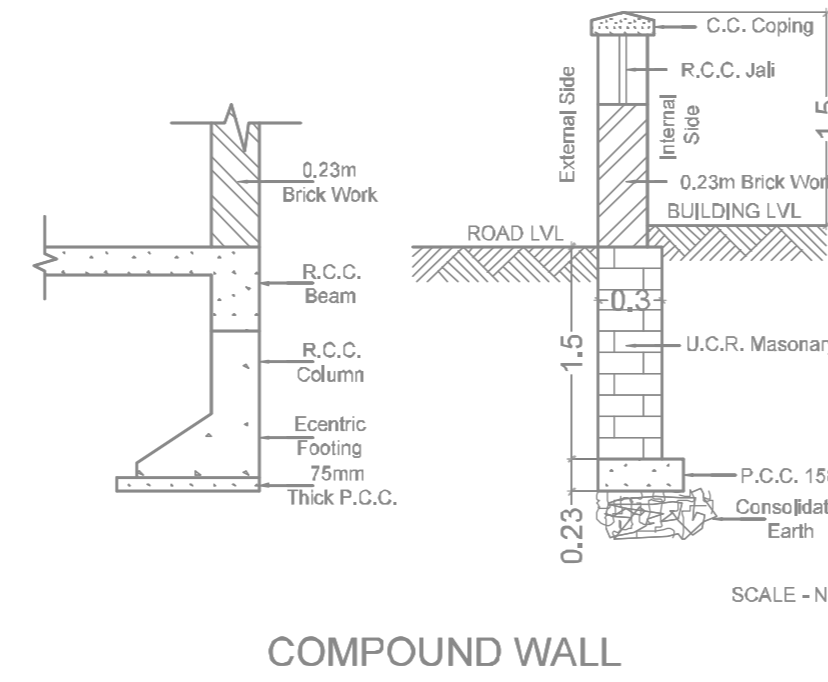
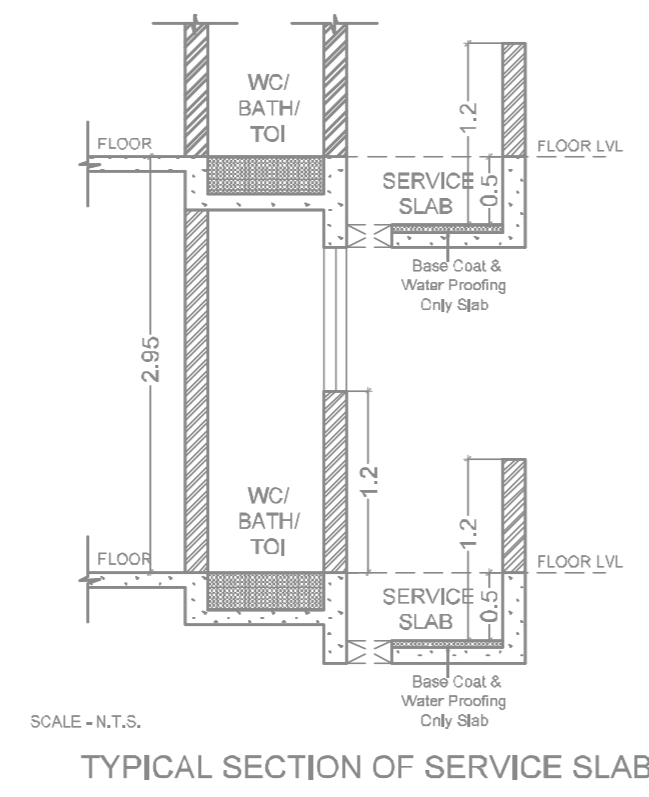

OWNER'S NAME			
M/S. PROGRESSIVE HOMES, THROUGH ITS PARTNERS, MR. JGAR D. TRIVEDI AND OTHERS THREE			
PROJECT INFORMATION			
PLOT NO. 80	SECTOR NO. 21		
MODE : Ume/Neu			
PROJECT TYPE:			
CONSULTANT NAME			
ATUL SATEL ARCHITECTS			
Page No.			
JOB NO.	DRG NO.	SCALE	DRAWN BY/CHECKED BY
INWARD NO.	CIDCO/BP-16301/TPO(NM&K)2019/3998	1:100	
KEY NO.	5-81	DATE	07-03-2019
		SHEET NO.	7/7