

Stamp of approval for the proposed project, including the name of the architect and the date of approval.

NOTES: This project is subject to the approval of the relevant authorities. The architect shall be responsible for obtaining all necessary permits and approvals.

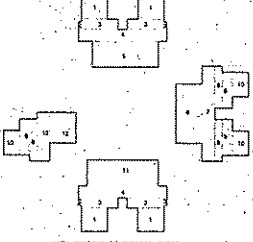
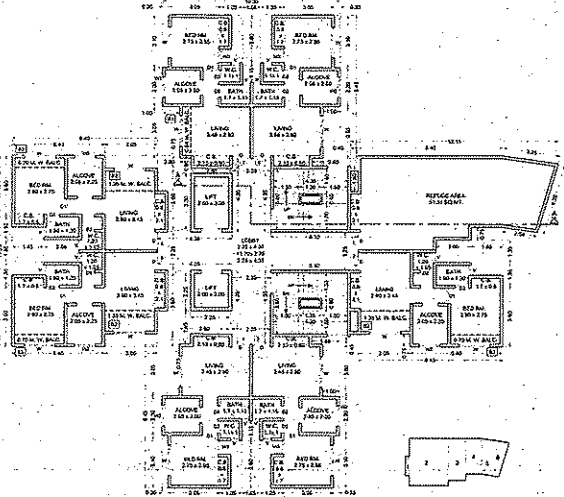

AREA DIAGRAM OF TYPICAL FLOOR

1ST, 12TH, 17TH & 22ND FLOOR

SCALE: 1:1000 SECTION A-A, B-B, C-C, D-D, E-E, F-F, G-G, H-H, I-I, J-J, K-K, L-L, M-M, N-N, O-O, P-P, Q-Q, R-R, S-S, T-T, U-U, V-V, W-W, X-X, Y-Y, Z-Z

Table with 2 columns: Room Name and Area. Lists various rooms and their respective areas.

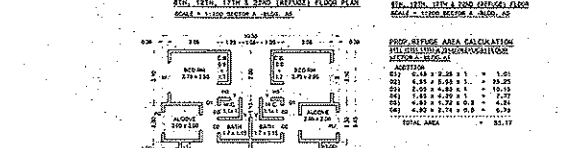

FLOOR AREA CALCULATION

1ST, 12TH, 17TH & 22ND FLOOR

SCALE: 1:1000 SECTION A-A, B-B, C-C, D-D, E-E, F-F, G-G, H-H, I-I, J-J, K-K, L-L, M-M, N-N, O-O, P-P, Q-Q, R-R, S-S, T-T, U-U, V-V, W-W, X-X, Y-Y, Z-Z

Table with 2 columns: Room Name and Area. Lists various rooms and their respective areas.

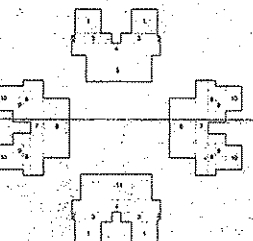
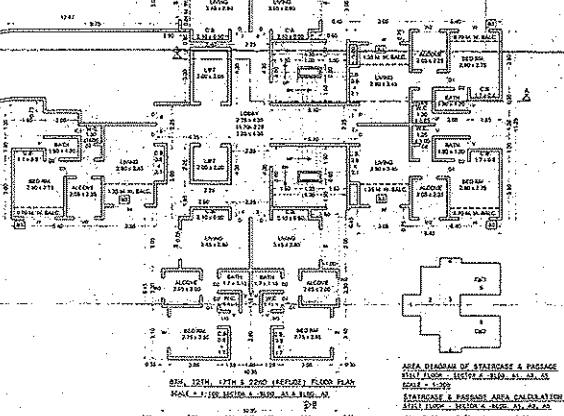

AREA DIAGRAM OF TYPICAL FLOOR

1ST, 12TH, 17TH & 22ND FLOOR

SCALE: 1:1000 SECTION A-A, B-B, C-C, D-D, E-E, F-F, G-G, H-H, I-I, J-J, K-K, L-L, M-M, N-N, O-O, P-P, Q-Q, R-R, S-S, T-T, U-U, V-V, W-W, X-X, Y-Y, Z-Z

Table with 2 columns: Room Name and Area. Lists various rooms and their respective areas.

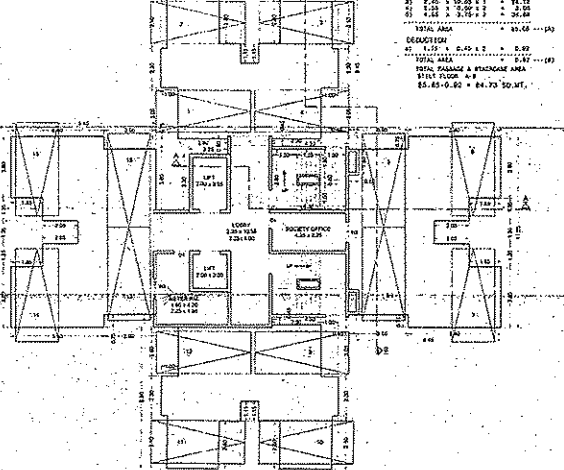

AREA DIAGRAM OF STAIRCASE & PASSAGE

1ST, 12TH, 17TH & 22ND FLOOR

SCALE: 1:1000 SECTION A-A, B-B, C-C, D-D, E-E, F-F, G-G, H-H, I-I, J-J, K-K, L-L, M-M, N-N, O-O, P-P, Q-Q, R-R, S-S, T-T, U-U, V-V, W-W, X-X, Y-Y, Z-Z

Table with 2 columns: Room Name and Area. Lists various rooms and their respective areas.

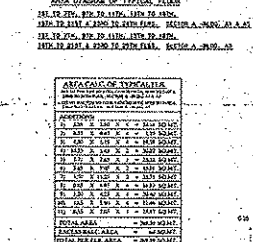

AREA DIAGRAM OF TYPICAL FLOOR

1ST, 12TH, 17TH & 22ND FLOOR

SCALE: 1:1000 SECTION A-A, B-B, C-C, D-D, E-E, F-F, G-G, H-H, I-I, J-J, K-K, L-L, M-M, N-N, O-O, P-P, Q-Q, R-R, S-S, T-T, U-U, V-V, W-W, X-X, Y-Y, Z-Z

Table with 2 columns: Room Name and Area. Lists various rooms and their respective areas.

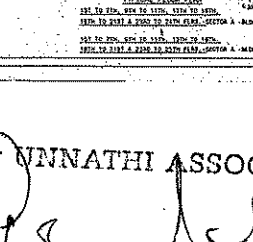
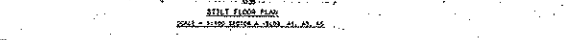

TYPICAL FLOOR PLAN

1ST, 12TH, 17TH & 22ND FLOOR

SCALE: 1:1000 SECTION A-A, B-B, C-C, D-D, E-E, F-F, G-G, H-H, I-I, J-J, K-K, L-L, M-M, N-N, O-O, P-P, Q-Q, R-R, S-S, T-T, U-U, V-V, W-W, X-X, Y-Y, Z-Z

Table with 2 columns: Room Name and Area. Lists various rooms and their respective areas.

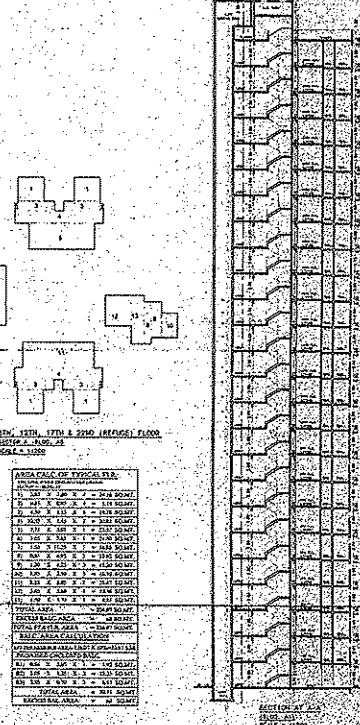

AREA DIAGRAM OF TYPICAL FLOOR

1ST, 12TH, 17TH & 22ND FLOOR

SCALE: 1:1000 SECTION A-A, B-B, C-C, D-D, E-E, F-F, G-G, H-H, I-I, J-J, K-K, L-L, M-M, N-N, O-O, P-P, Q-Q, R-R, S-S, T-T, U-U, V-V, W-W, X-X, Y-Y, Z-Z

Table with 2 columns: Room Name and Area. Lists various rooms and their respective areas.

AREA DIAGRAM OF TYPICAL FLOOR

1ST, 12TH, 17TH & 22ND FLOOR

SCALE: 1:1000 SECTION A-A, B-B, C-C, D-D, E-E, F-F, G-G, H-H, I-I, J-J, K-K, L-L, M-M, N-N, O-O, P-P, Q-Q, R-R, S-S, T-T, U-U, V-V, W-W, X-X, Y-Y, Z-Z

Table with 2 columns: Room Name and Area. Lists various rooms and their respective areas.

AREA DIAGRAM OF STAIRCASE & PASSAGE

1ST, 12TH, 17TH & 22ND FLOOR

SCALE: 1:1000 SECTION A-A, B-B, C-C, D-D, E-E, F-F, G-G, H-H, I-I, J-J, K-K, L-L, M-M, N-N, O-O, P-P, Q-Q, R-R, S-S, T-T, U-U, V-V, W-W, X-X, Y-Y, Z-Z

Table with 2 columns: Room Name and Area. Lists various rooms and their respective areas.

CONTENTS OF DRAWING

Table listing the contents of the drawing, including floor plans, area diagrams, and staircase & passage area diagrams.

For ANNATHI ASSOCIATES

Handwritten signature of the partner.

PARTNER

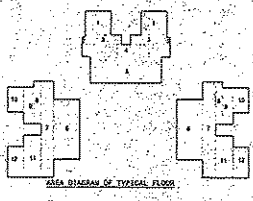
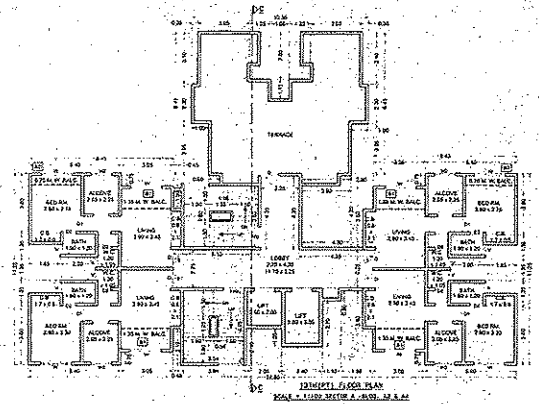

AREA DIAGRAM OF TYPICAL FLOOR

1ST TO 2ND FLOOR - SECTION A-B, AS SHOWN ON P. 3/18

NO.	DESCRIPTION	AREA (SQ. FT.)
1	1ST FLOOR AREA	11,250.00
2	2ND FLOOR AREA	11,250.00
3	STAIRCASE & PASSAGE	1,500.00
4	ROOF AREA	11,250.00
5	TOTAL AREA	35,250.00

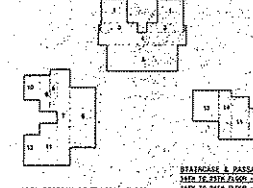
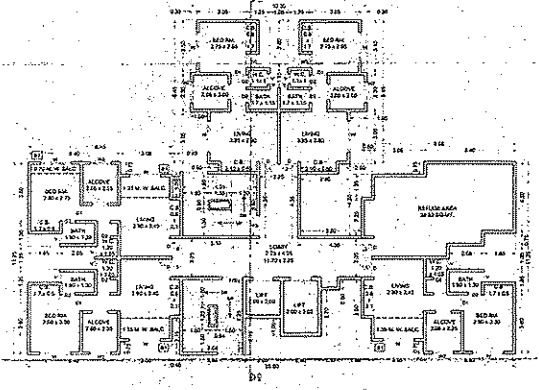

AREA DIAGRAM OF TYPICAL FLOOR

2ND TO 3RD FLOOR - SECTION A-B, AS SHOWN ON P. 3/18

NO.	DESCRIPTION	AREA (SQ. FT.)
1	2ND FLOOR AREA	11,250.00
2	3RD FLOOR AREA	11,250.00
3	STAIRCASE & PASSAGE	1,500.00
4	ROOF AREA	11,250.00
5	TOTAL AREA	35,250.00

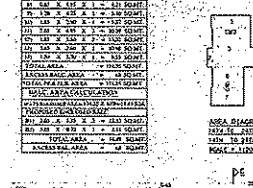
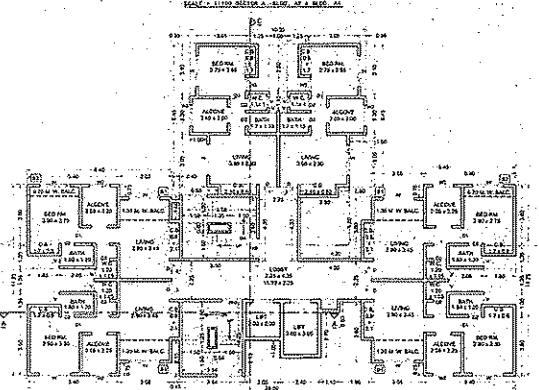

AREA DIAGRAM OF TYPICAL FLOOR

3RD TO 4TH FLOOR - SECTION A-B, AS SHOWN ON P. 3/18

NO.	DESCRIPTION	AREA (SQ. FT.)
1	3RD FLOOR AREA	11,250.00
2	4TH FLOOR AREA	11,250.00
3	STAIRCASE & PASSAGE	1,500.00
4	ROOF AREA	11,250.00
5	TOTAL AREA	35,250.00

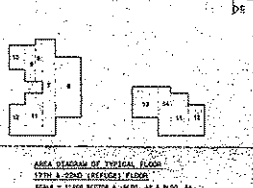
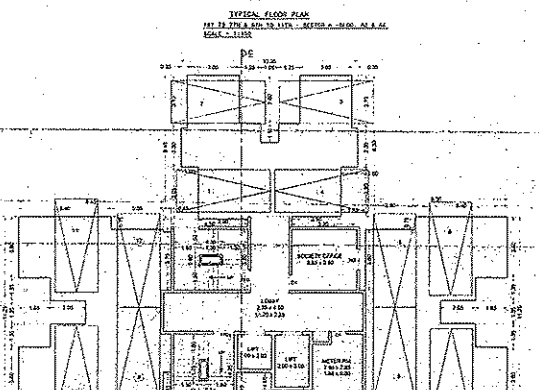

AREA DIAGRAM OF TYPICAL FLOOR

4TH TO 5TH FLOOR - SECTION A-B, AS SHOWN ON P. 3/18

NO.	DESCRIPTION	AREA (SQ. FT.)
1	4TH FLOOR AREA	11,250.00
2	5TH FLOOR AREA	11,250.00
3	STAIRCASE & PASSAGE	1,500.00
4	ROOF AREA	11,250.00
5	TOTAL AREA	35,250.00

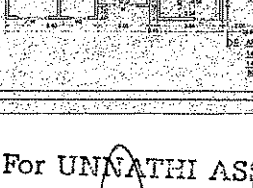
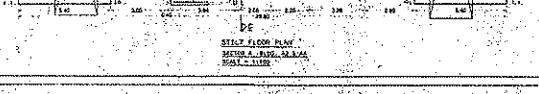

AREA DIAGRAM OF TYPICAL FLOOR

5TH TO 6TH FLOOR - SECTION A-B, AS SHOWN ON P. 3/18

NO.	DESCRIPTION	AREA (SQ. FT.)
1	5TH FLOOR AREA	11,250.00
2	6TH FLOOR AREA	11,250.00
3	STAIRCASE & PASSAGE	1,500.00
4	ROOF AREA	11,250.00
5	TOTAL AREA	35,250.00

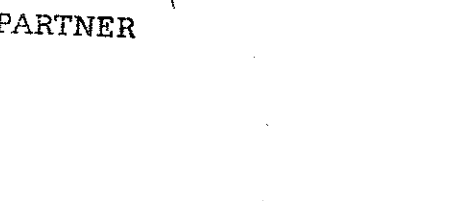
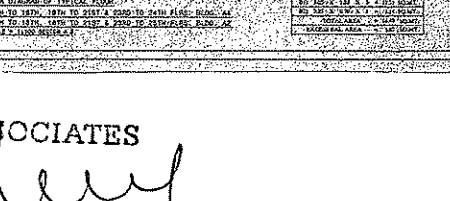
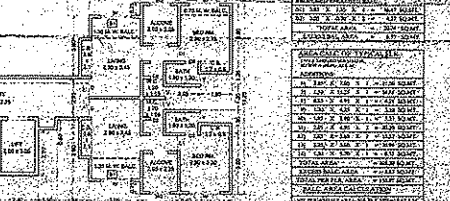
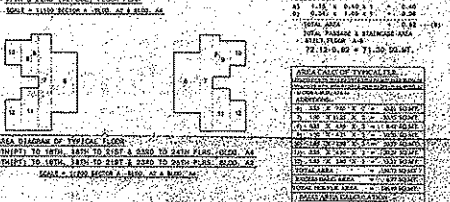
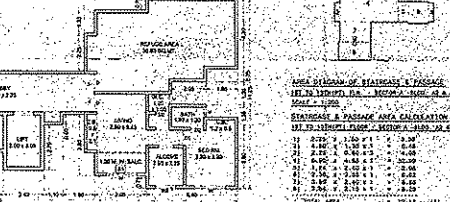
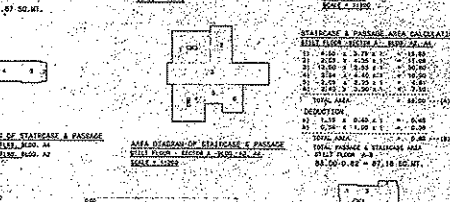
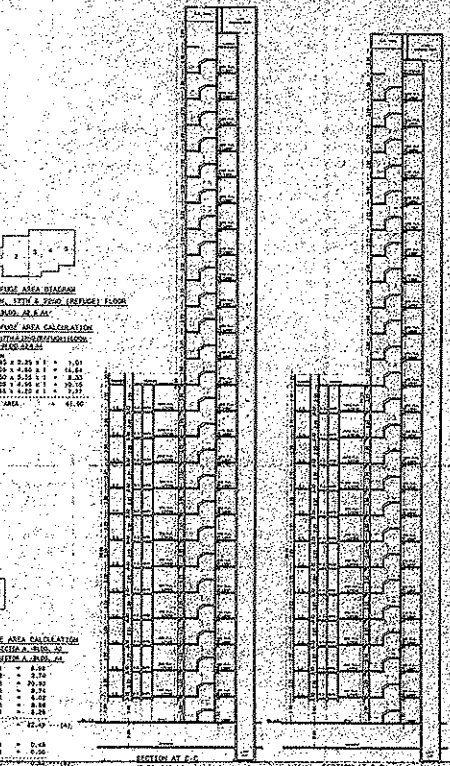

PROVISIONAL
STAMP OF APPROVAL OF PLANS
 APPROVED BY:
 MUNICIPAL ENGINEER
 MUNICIPALITY OF CHENNAI
 PROJECT NO. 123456789
 DATE: 10/10/2024

NOTICE
 Any person who is not the owner of the property and who is not a member of the committee of the project shall not be allowed to work on the site.

STAIRCASE & PASSAGE AREA CALCULATION

NO.	DESCRIPTION	AREA (SQ. FT.)
1	STAIRCASE	1,500.00
2	PASSAGE	1,500.00
3	TOTAL	3,000.00

STAIRCASE & PASSAGE AREA CALCULATION

NO.	DESCRIPTION	AREA (SQ. FT.)
1	STAIRCASE	1,500.00
2	PASSAGE	1,500.00
3	TOTAL	3,000.00

STAIRCASE & PASSAGE AREA CALCULATION

NO.	DESCRIPTION	AREA (SQ. FT.)
1	STAIRCASE	1,500.00
2	PASSAGE	1,500.00
3	TOTAL	3,000.00

STAIRCASE & PASSAGE AREA CALCULATION

NO.	DESCRIPTION	AREA (SQ. FT.)
1	STAIRCASE	1,500.00
2	PASSAGE	1,500.00
3	TOTAL	3,000.00

STAIRCASE & PASSAGE AREA CALCULATION

NO.	DESCRIPTION	AREA (SQ. FT.)
1	STAIRCASE	1,500.00
2	PASSAGE	1,500.00
3	TOTAL	3,000.00

STAIRCASE & PASSAGE AREA CALCULATION

NO.	DESCRIPTION	AREA (SQ. FT.)
1	STAIRCASE	1,500.00
2	PASSAGE	1,500.00
3	TOTAL	3,000.00

STAIRCASE & PASSAGE AREA CALCULATION

NO.	DESCRIPTION	AREA (SQ. FT.)
1	STAIRCASE	1,500.00
2	PASSAGE	1,500.00
3	TOTAL	3,000.00

STAIRCASE & PASSAGE AREA CALCULATION

NO.	DESCRIPTION	AREA (SQ. FT.)
1	STAIRCASE	1,500.00
2	PASSAGE	1,500.00
3	TOTAL	3,000.00

STAIRCASE & PASSAGE AREA CALCULATION

NO.	DESCRIPTION	AREA (SQ. FT.)
1	STAIRCASE	1,500.00
2	PASSAGE	1,500.00
3	TOTAL	3,000.00

For UNNATHI ASSOCIATES
[Signature]
 PARTNER

