

बांधकाम नकाशा मंजुरी
 रजिस्ट्रार
 रजिस्ट्रार कार्यालय
 प्लॉट नं. 91, फर्स्ट फ्लोर, नवी/बॉय/कॉम्प्लेक्स, 2022-92/801869
 दिनांक 20/09/2023
 दिलेल्या अटीप्रमाणे

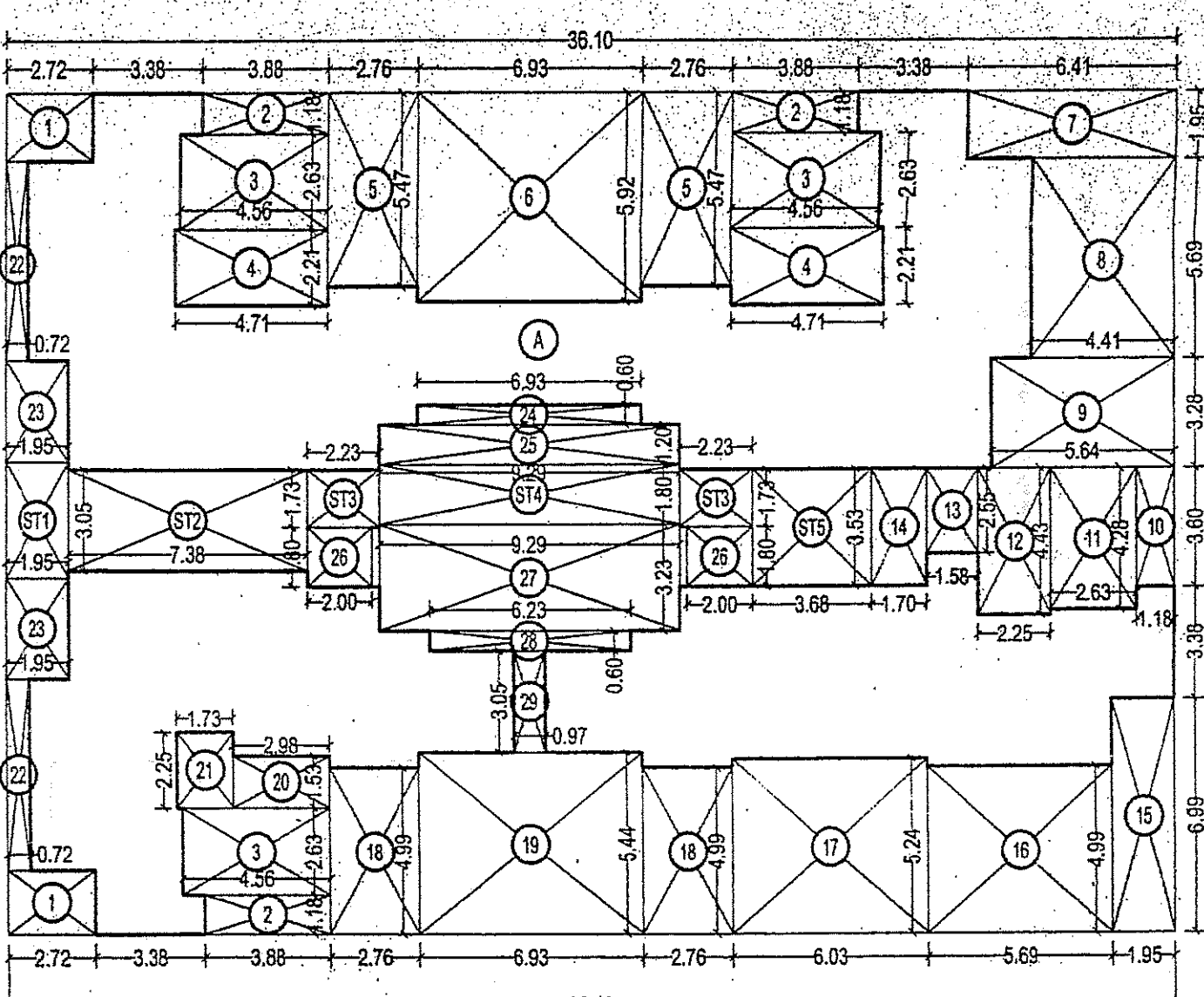

सहायक रजिस्ट्रार
 श. रमण कल्याण चौक, नवी/बॉय/कॉम्प्लेक्स

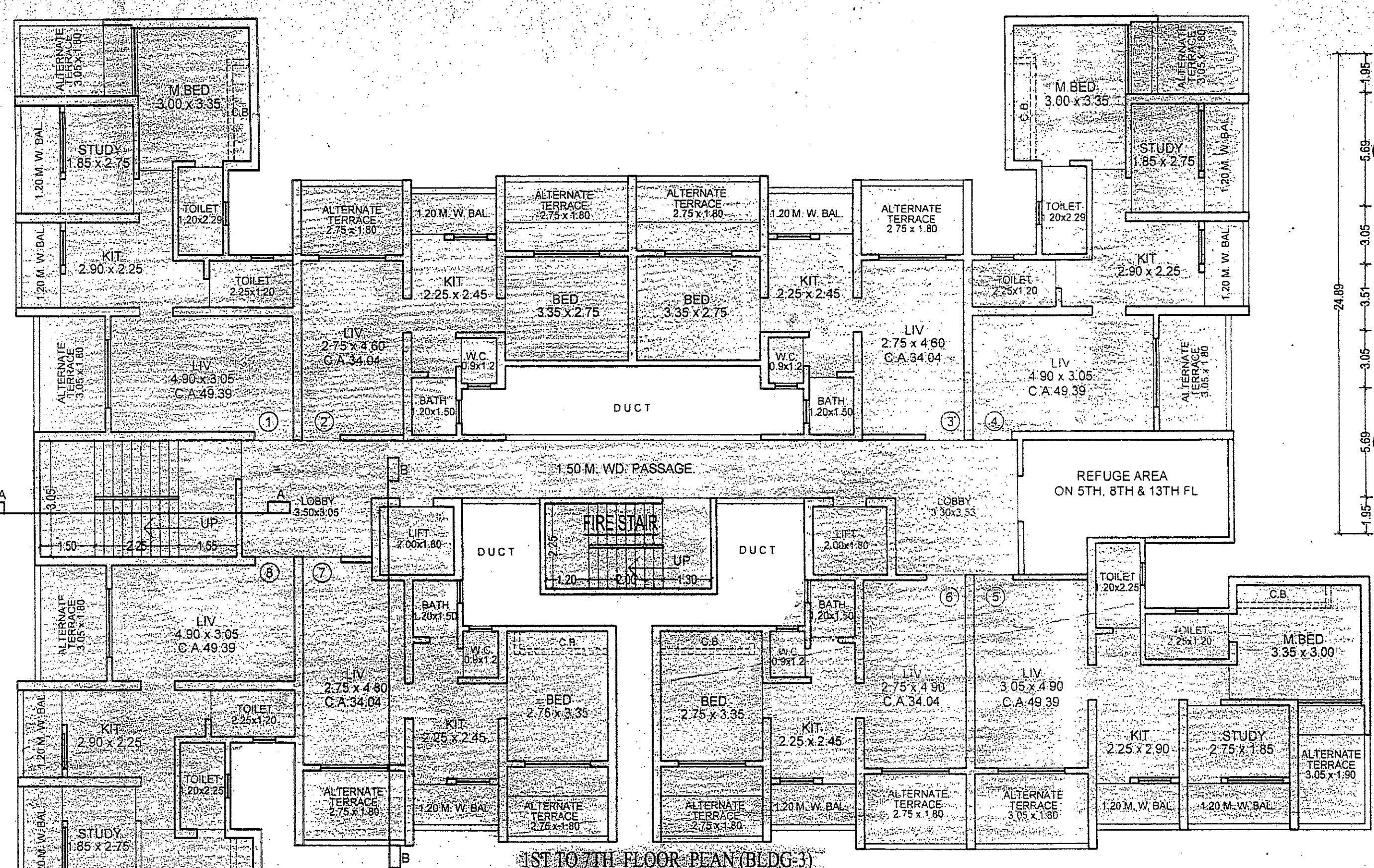
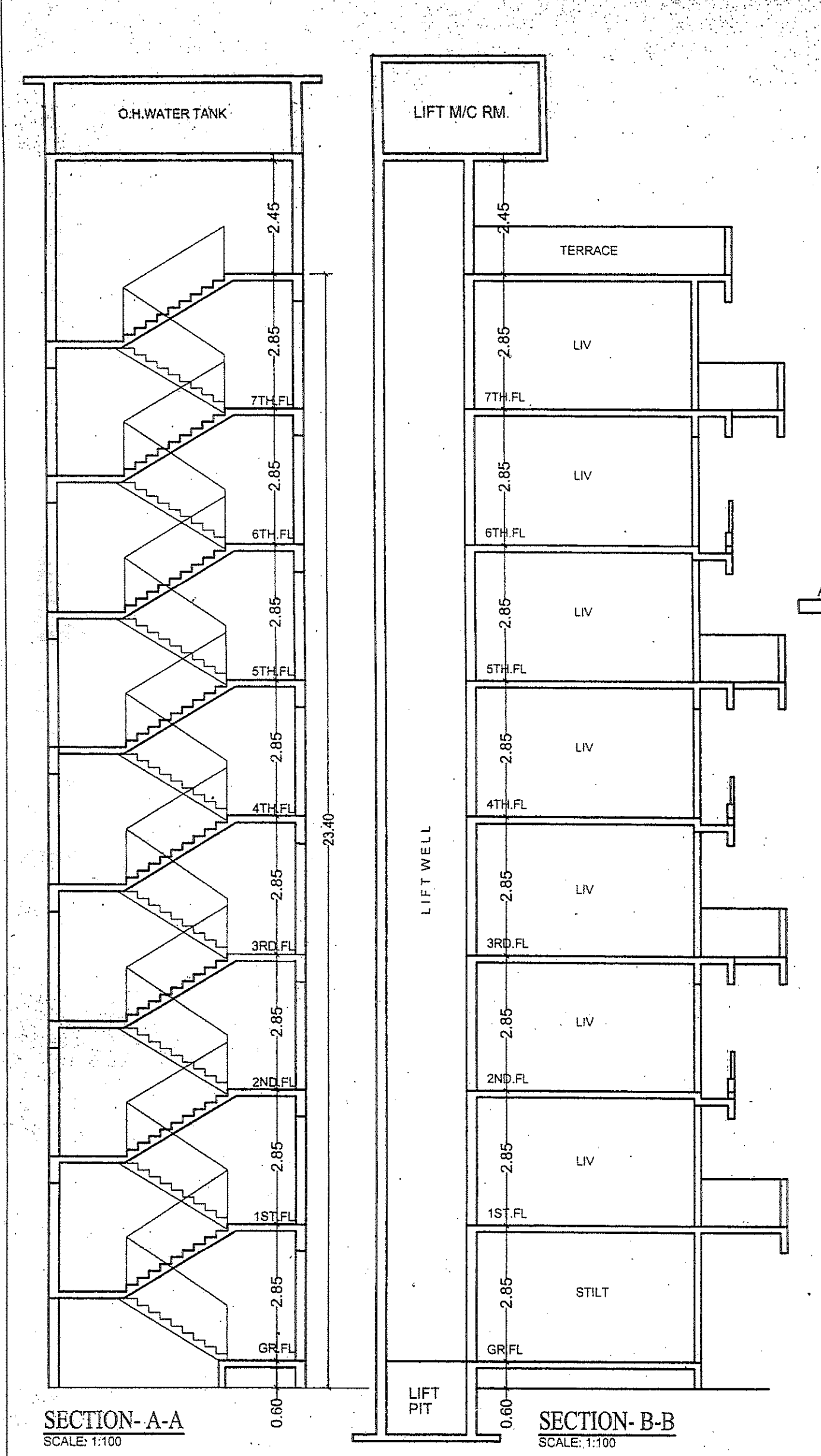

AREA DIAGRAM FOR 1ST TO 14TH FLOOR (BLDG-3)
 SCALE: 1:200

BUILT UP AREA CALCULATION

NO.	DESCRIPTION	NO.	AREA (SQ.MT)
1	1.50 M. X 24.88 X 1 NO.	1	37.32
2	2.72 X 1.85 X 2 NOS.	2	10.01
3	2.38 X 1.18 X 3 NOS.	3	8.37
4	4.98 X 2.83 X 3 NOS.	4	42.33
5	4.71 X 2.21 X 2 NOS.	5	20.82
6	2.78 X 5.47 X 2 NOS.	6	30.19
7	6.65 X 1.95 X 1 NO.	7	12.90
8	4.41 X 5.89 X 1 NO.	8	25.89
9	5.54 X 3.28 X 1 NO.	9	18.20
10	1.18 X 3.69 X 1 NO.	10	4.35
11	2.63 X 4.28 X 1 NO.	11	11.28
12	2.25 X 4.43 X 1 NO.	12	10.00
13	1.58 X 2.25 X 1 NO.	13	3.55
14	1.10 X 5.53 X 1 NO.	14	6.08
15	1.85 X 6.89 X 1 NO.	15	12.74
16	5.69 X 4.99 X 1 NO.	16	28.39
17	6.93 X 5.24 X 1 NO.	17	36.31
18	2.78 X 4.99 X 2 NOS.	18	27.54
19	6.93 X 5.44 X 1 NO.	19	37.70
20	2.98 X 1.93 X 1 NO.	20	5.75
21	1.10 X 2.25 X 1 NO.	21	2.48
22	0.72 X 5.89 X 2 NOS.	22	8.49
23	1.85 X 3.05 X 2 NOS.	23	11.30
24	6.93 X 6.89 X 1 NO.	24	47.55
25	9.22 X 1.20 X 1 NO.	25	11.06
26	2.00 X 1.80 X 2 NOS.	26	7.20
27	9.29 X 3.23 X 1 NO.	27	30.01
28	6.29 X 6.89 X 1 NO.	28	43.34
29	0.97 X 3.05 X 1 NO.	29	2.96
30	TOTAL ADDITION		470.59
31	TOTAL DEDUCTION		427.94
32	NET BUILT UP AREA		42.65

STAIRCASE AREA STATEMENT (BLDG-3)

FLOOR	B-UP AREA IN SQ.MT	STAIRCASE AREA
GROUND FLR	-	63.41
1ST FLR	361.16	66.78
2ND FLR	361.16	66.78
3RD FLR	361.16	66.78
4TH FLR	361.16	66.78
5TH FLR	361.16	66.78
6TH FLR	361.16	66.78
7TH FLR	361.16	66.78
TOTAL AREA	2528.12	530.87 SQ.M.

SUMMARY & BALCONY AREA STATEMENT (BLDG-3)

FLOOR	B-UP AREA IN SQ.MT	PERM. AREA (10% OF B.U.A)	PROP. AREA	EXCESS AREA
GROUND FLR	-	-	-	-
1ST FLR	361.16	36.11	33.80	40.56
2ND FLR	361.16	36.11	33.80	40.56
3RD FLR	361.16	36.11	33.80	40.56
4TH FLR	361.16	36.11	33.80	40.56
5TH FLR	361.16	36.11	33.80	40.56
6TH FLR	361.16	36.11	33.80	40.56
7TH FLR	361.16	36.11	33.80	40.56
TOTAL AREA	2528.12	252.77	283.92	31.15

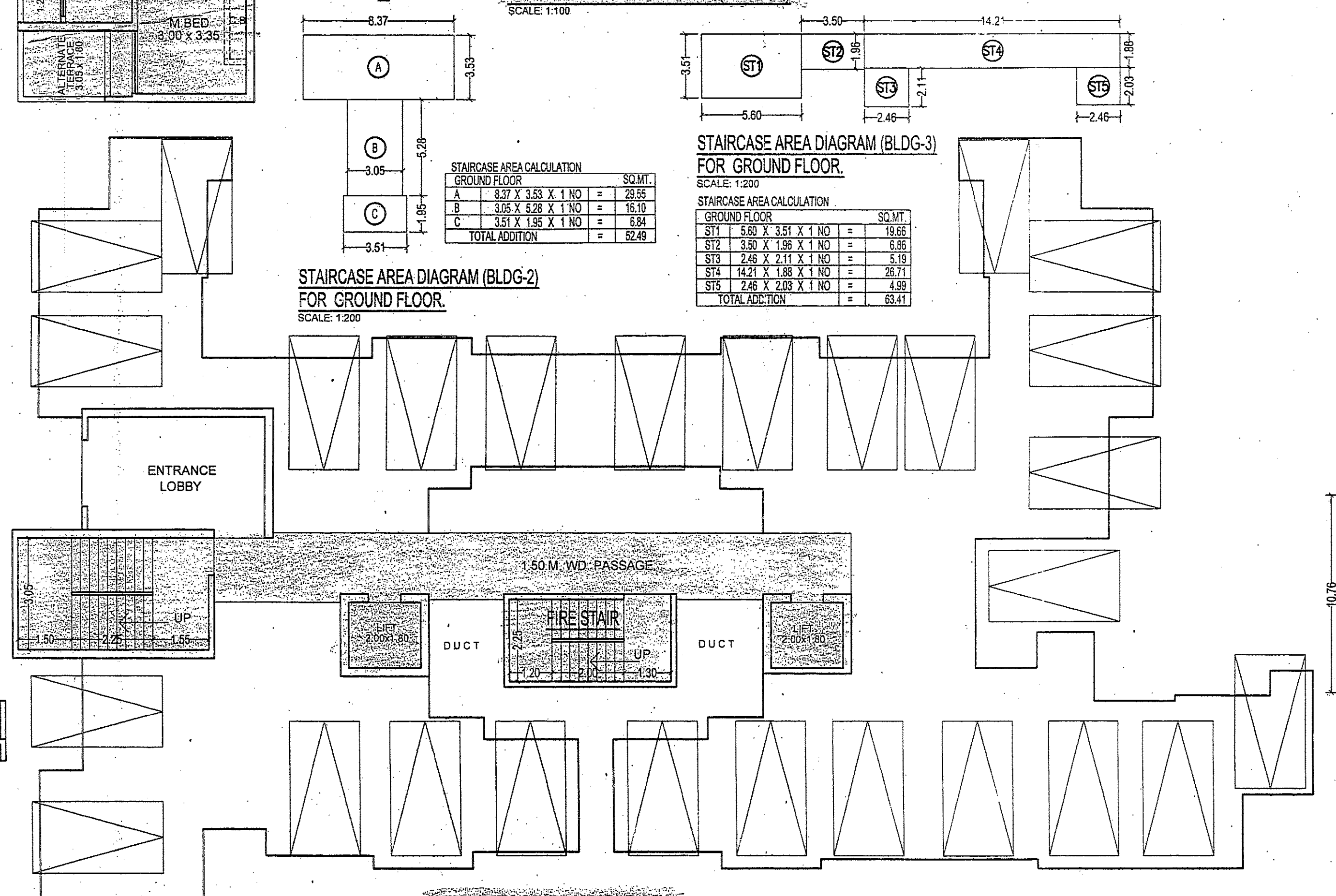
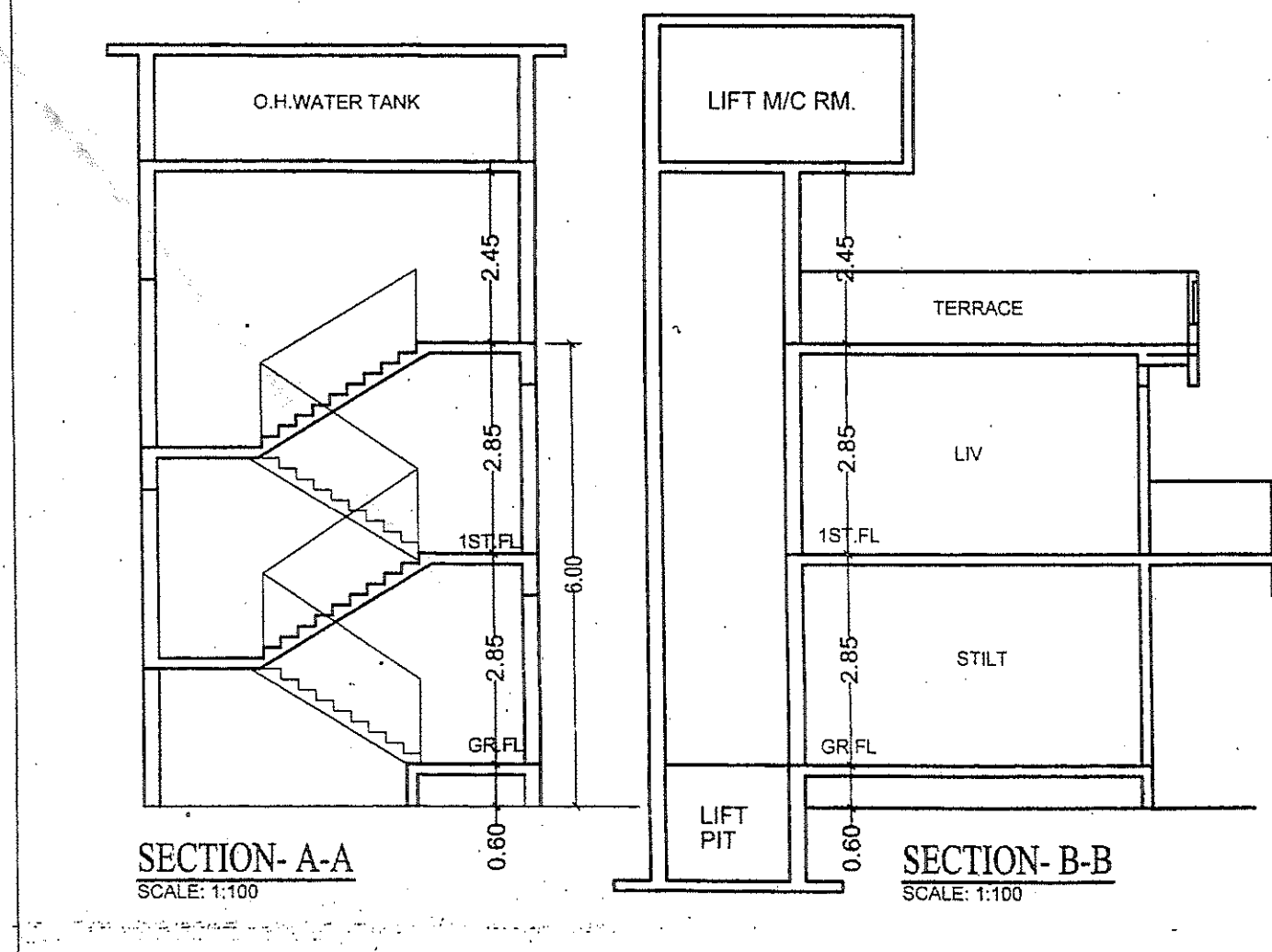

STAIRCASE AREA STATEMENT (BLDG-2)

FLOOR	B-UP AREA IN SQ.MT	STAIRCASE AREA
GROUND FLR	-	52.49
1ST FLR	209.74	56.51
TOTAL AREA	209.74	109.00 SQ.M.

SUMMARY & BALCONY AREA STATEMENT (BLDG-2)

FLOOR	B-UP AREA IN SQ.MT	PERM. AREA (10% OF B.U.A)	PROP. AREA	EXCESS AREA
GROUND FLR	-	-	-	-
1ST FLR	209.74	20.97	18.88	5.21
TOTAL AREA	209.74	20.97	26.18	5.21

STAIRCASE AREA STATEMENT (BLDG-2)

FLOOR	B-UP AREA IN SQ.MT	STAIRCASE AREA
GROUND FLR	-	52.49
1ST FLR	209.74	56.51
TOTAL AREA	209.74	109.00 SQ.M.

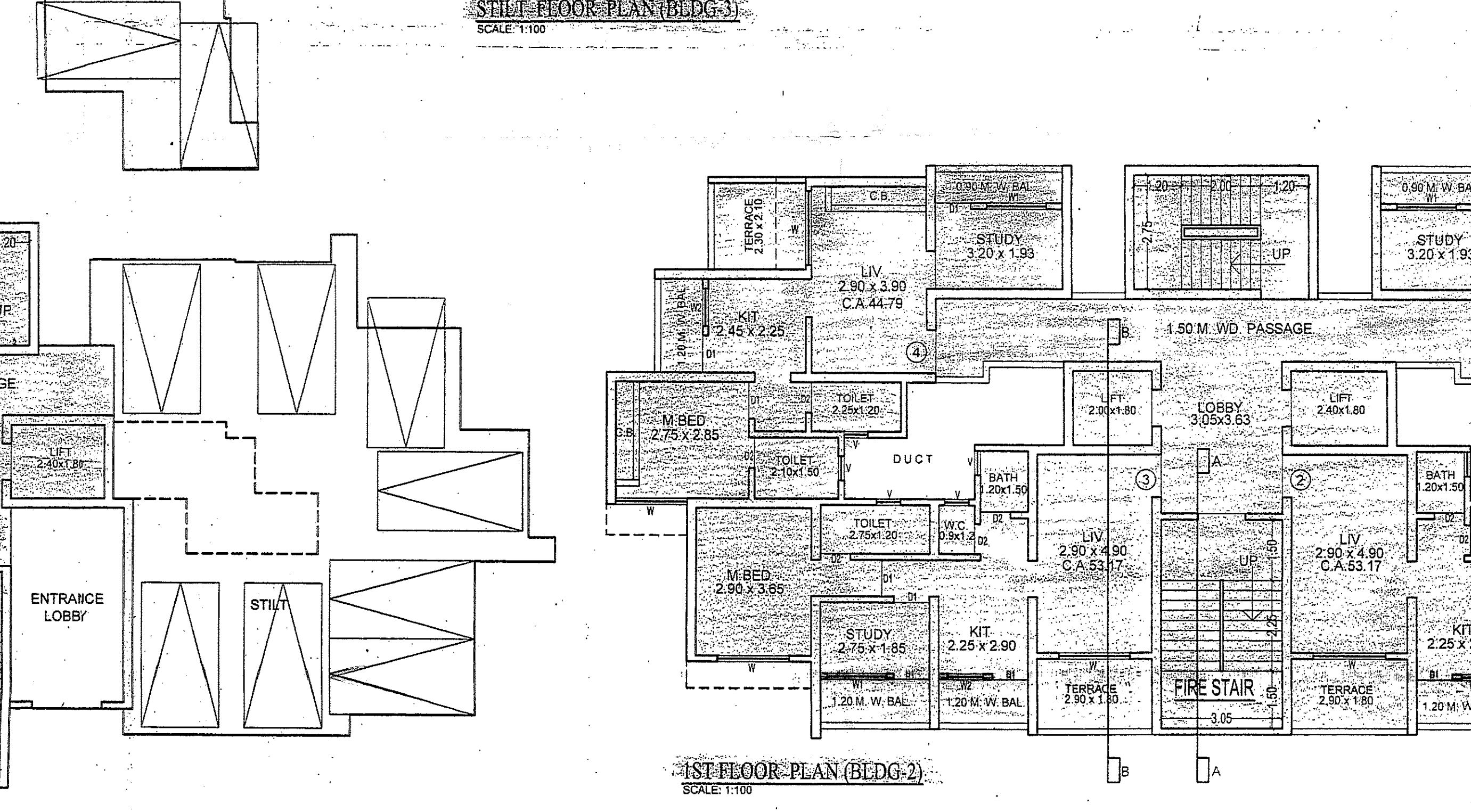
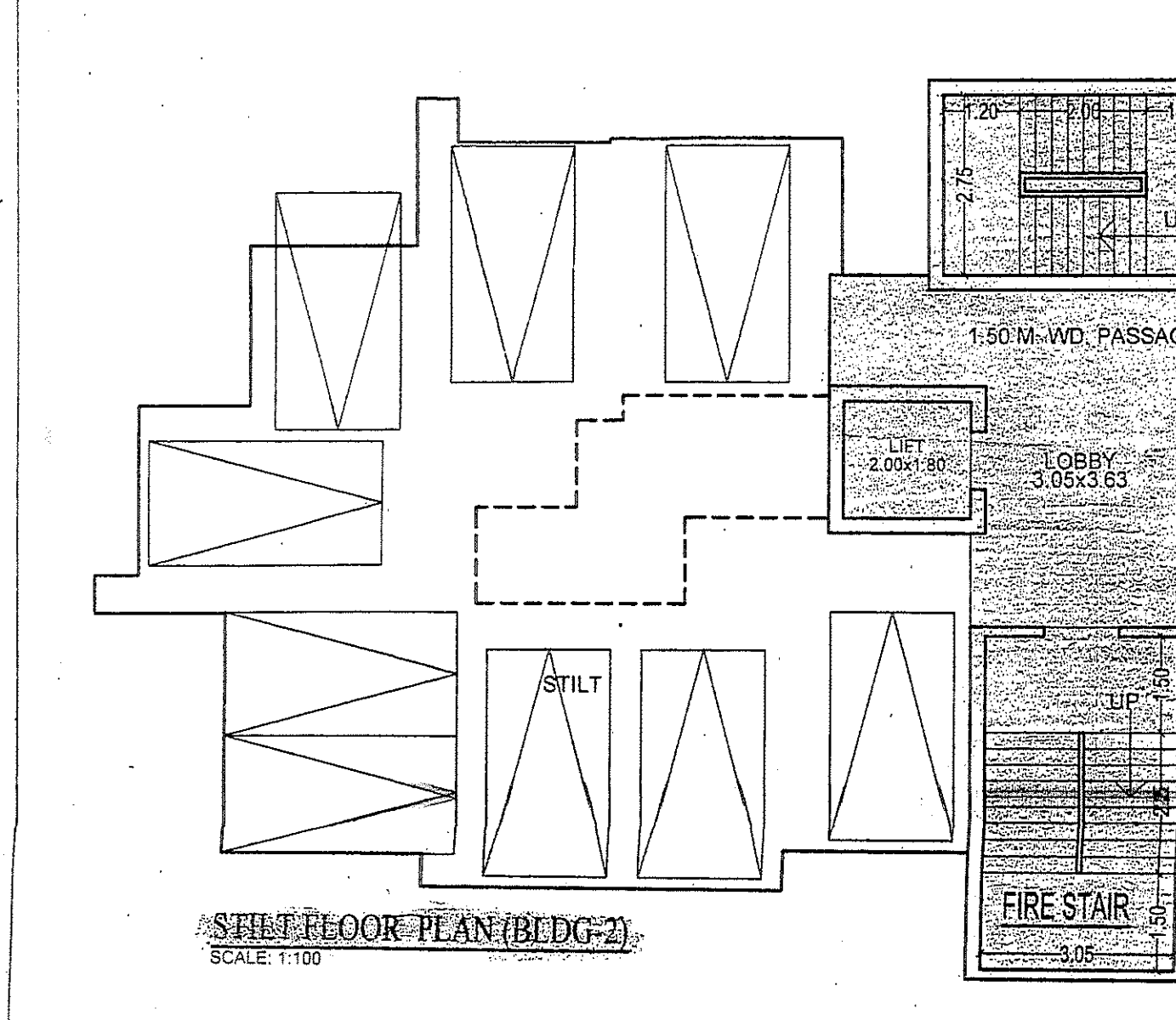
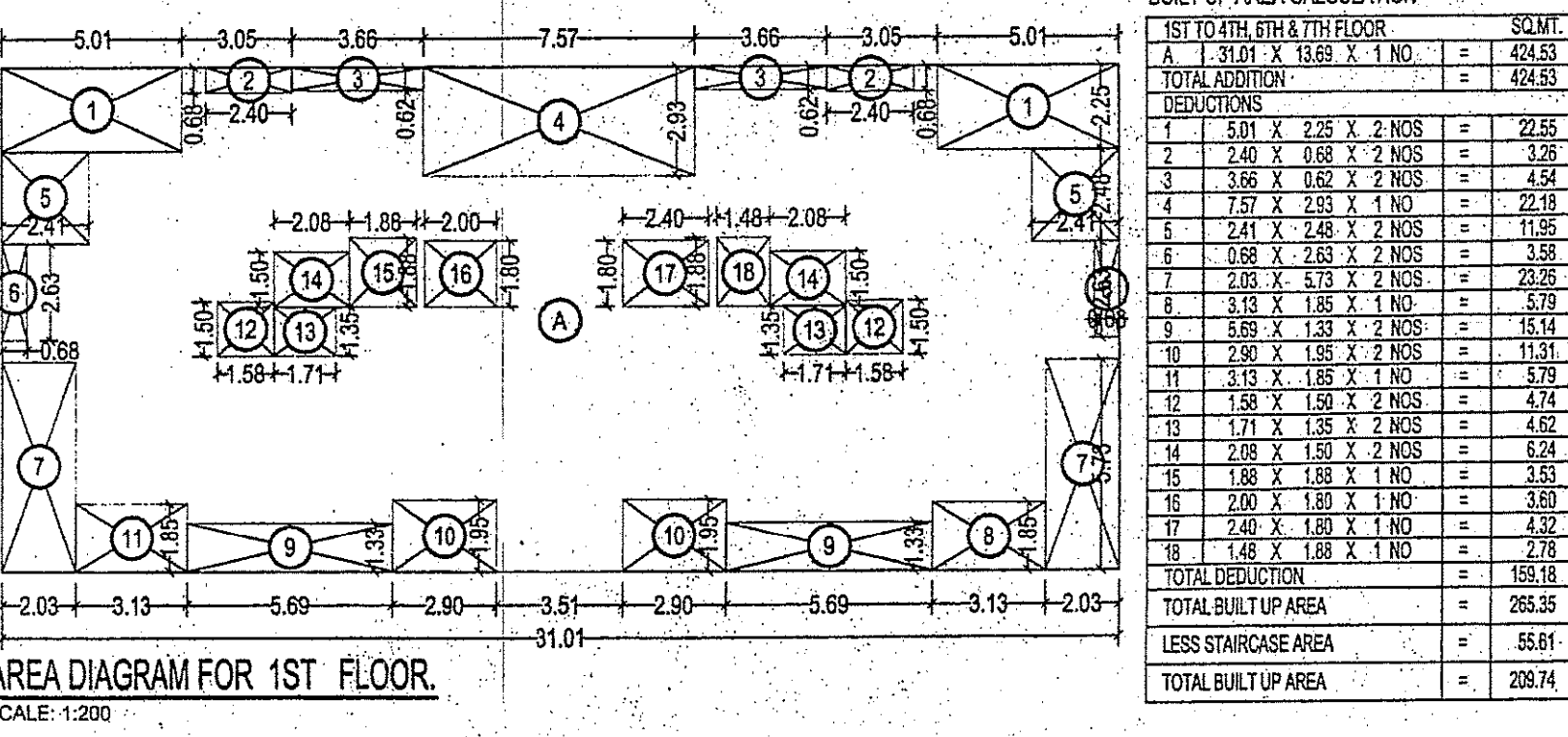

STAIRCASE AREA STATEMENT (BLDG-2)

FLOOR	B-UP AREA IN SQ.MT	STAIRCASE AREA
GROUND FLR	-	52.49
1ST FLR	209.74	56.51
TOTAL AREA	209.74	109.00 SQ.M.

STAIRCASE AREA STATEMENT (BLDG-2)

FLOOR	B-UP AREA IN SQ.MT	STAIRCASE AREA
GROUND FLR	-	52.49
1ST FLR	209.74	56.51
TOTAL AREA	209.74	109.00 SQ.M.

SHANTI CONSULTANTS
 P. C. Structural Engineers-Arvid S. Patel
 Reg. No. ST4/P87, KDMC Reg. No. 475

NAME & SIGNATURE OF OWNER
 Dip. Sanyambhu Siddhiviney Builders and Developers
 Partner

DESCRIPTION OF PROPOSAL & PROPERTY
 PROPOSED BUILDING ON PLOT BEARING OLD S.NO.135, NEW S.NO.92, & OLD S.NO.136, NEW S.NO.91, (PLOT-B) & OLD S.NO.81, NEW S.No.93, H.No.3 & 5 MOUJE-KANCHANGAON, TAL-KALYAN, DIST.-THANE, HOUSE NO. WARD NO. SECTOR-NO.5.

FOR: SRI SATYAWAN SHEPAT FARDE & SRI SHALIK CHANDRYA MEHRE

JOB NO.	DRG No.	SCALE	DRAWN BY	CHECKED BY	DATE
1018	2	AS STATED	KARTHIK		02-01-17

NAME & SIGNATURE OF ARCHITECT
 RACHANA ARCH
 D.R. BHOSALE
 CA / 2002 / 23737