

FRONT ELEVATION

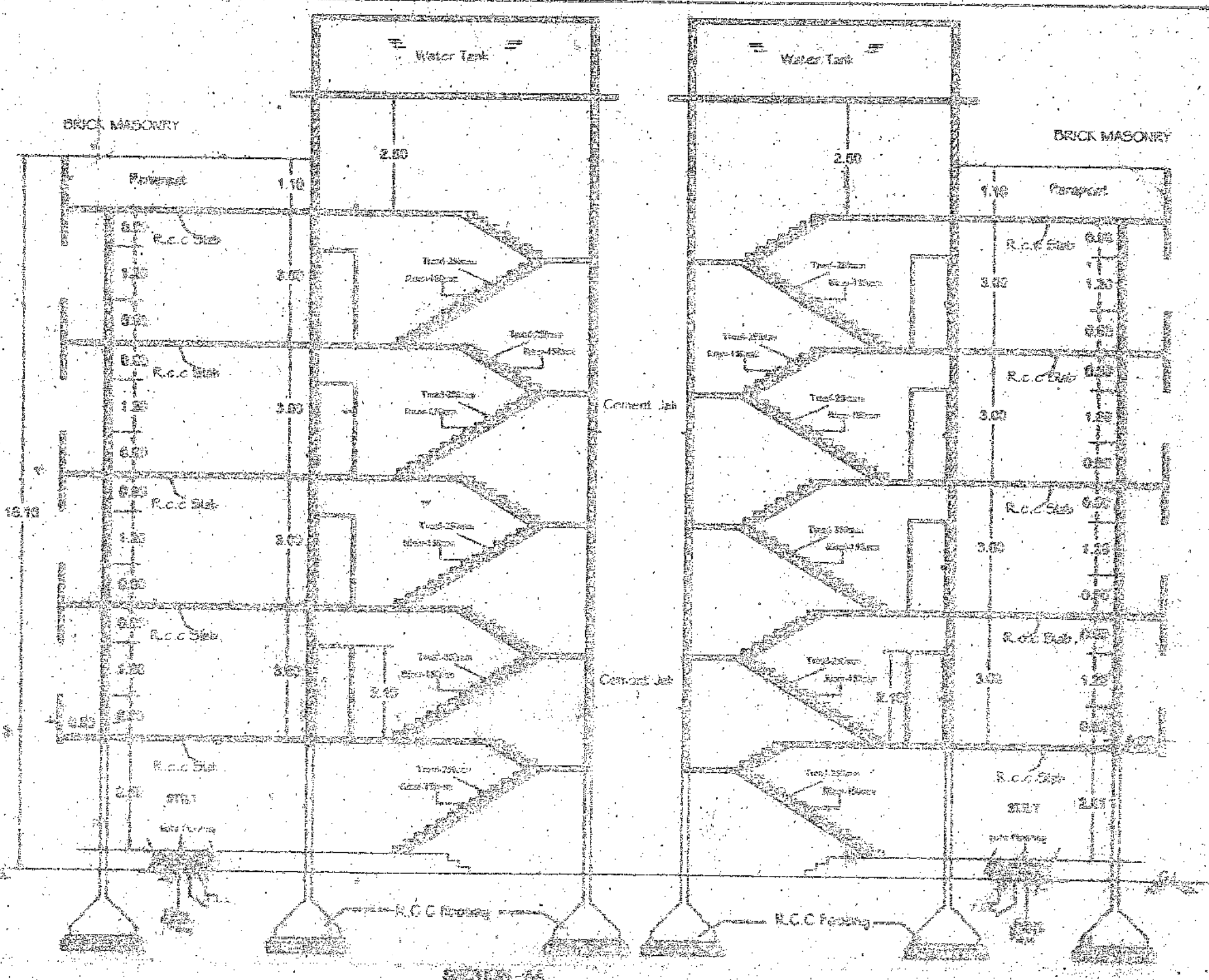

CROSS SECTION - A-A

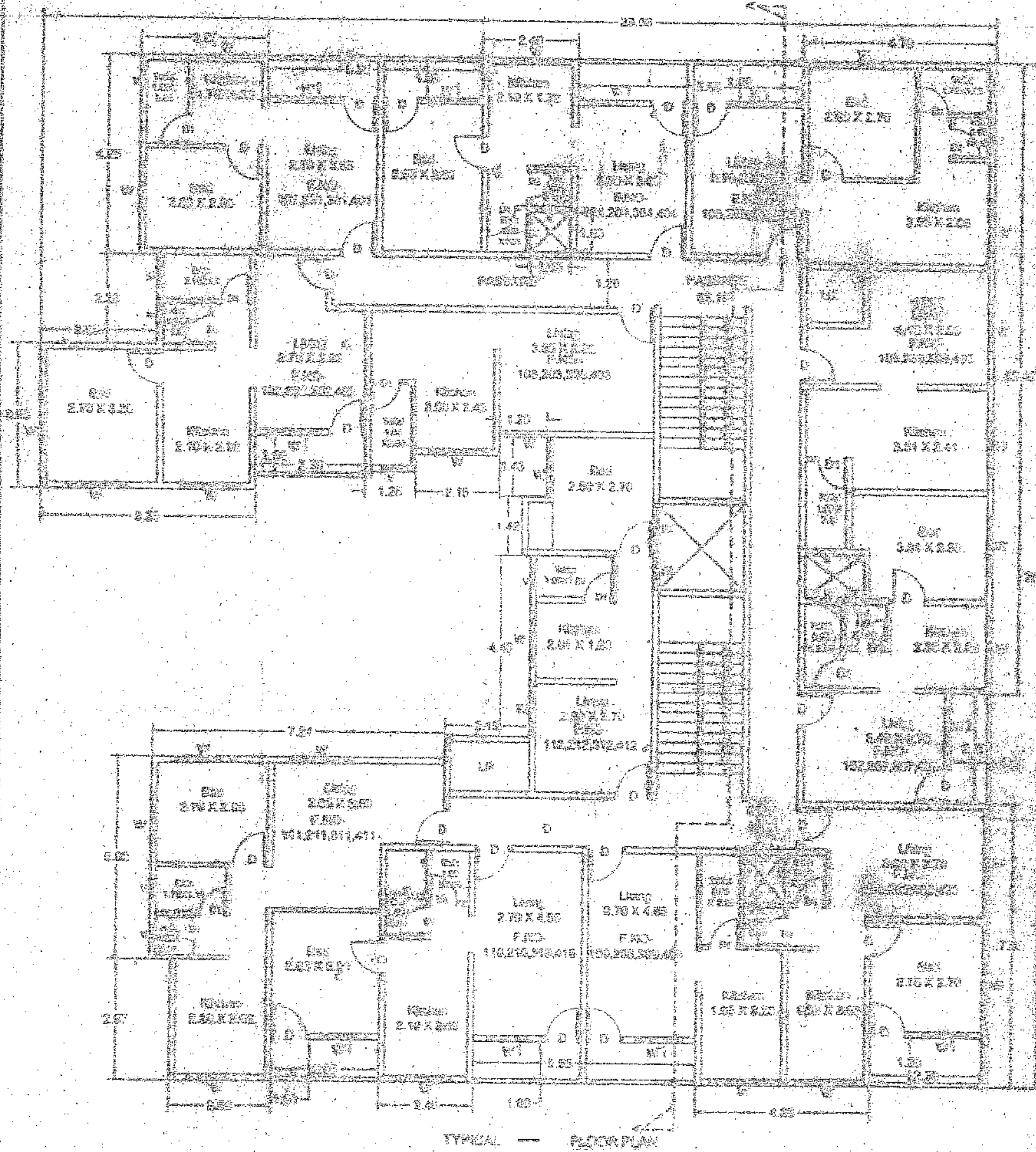

TYPICAL FLOOR PLAN

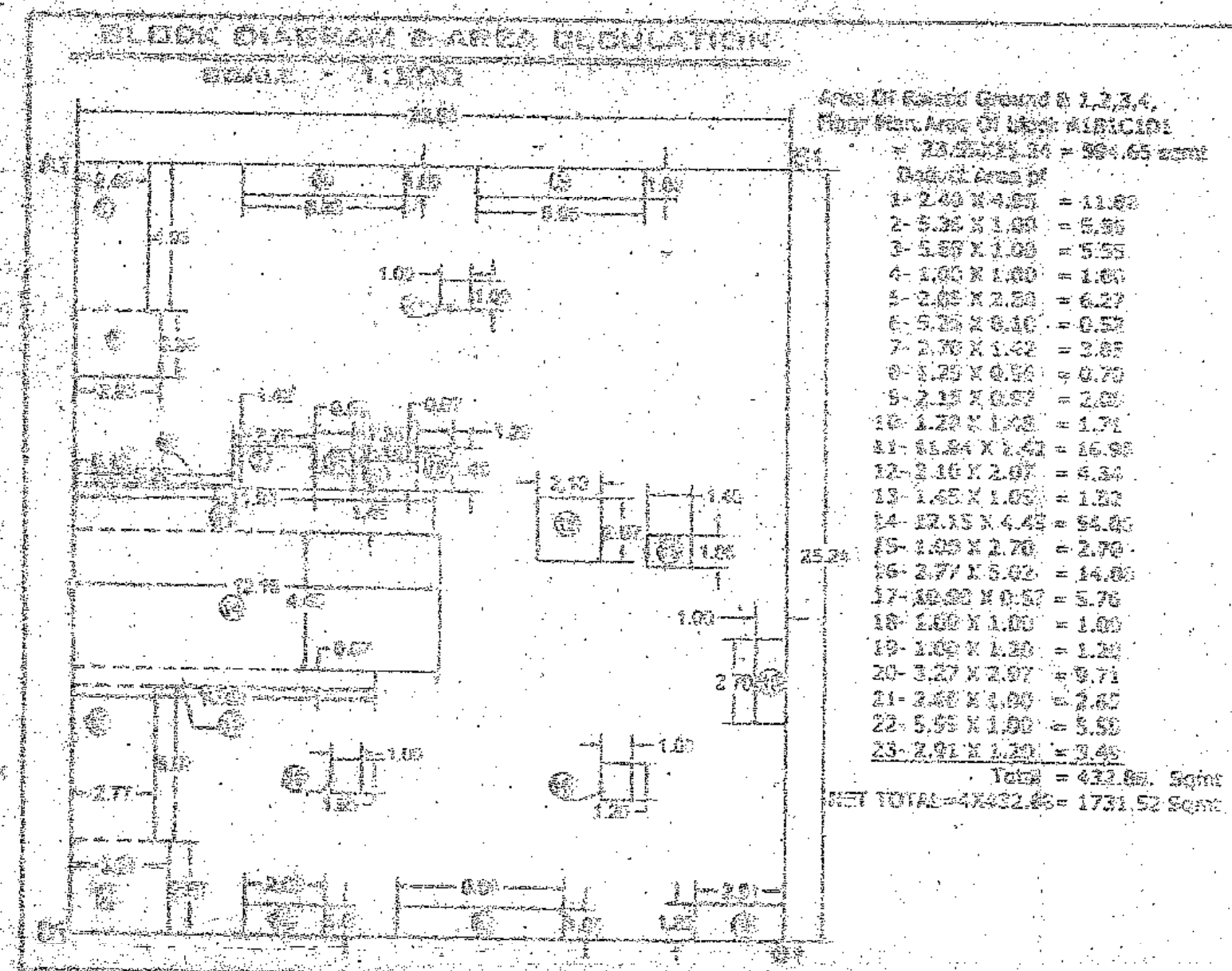

Sl. No.	Plot No.	Name of the Owner	Area of Enclosed Structure	Area of Open Plot	Total Area in Sqm
1	747/1	PRASADHAR MURUGAN MANDU	454.82 sqm	2754.80	3194.00
2	114/1	PRASADHAR SOLAYA MANDU	250.00 sqm	2300.00	2550.00

Total = 5994.00 = 599.40 Sqm

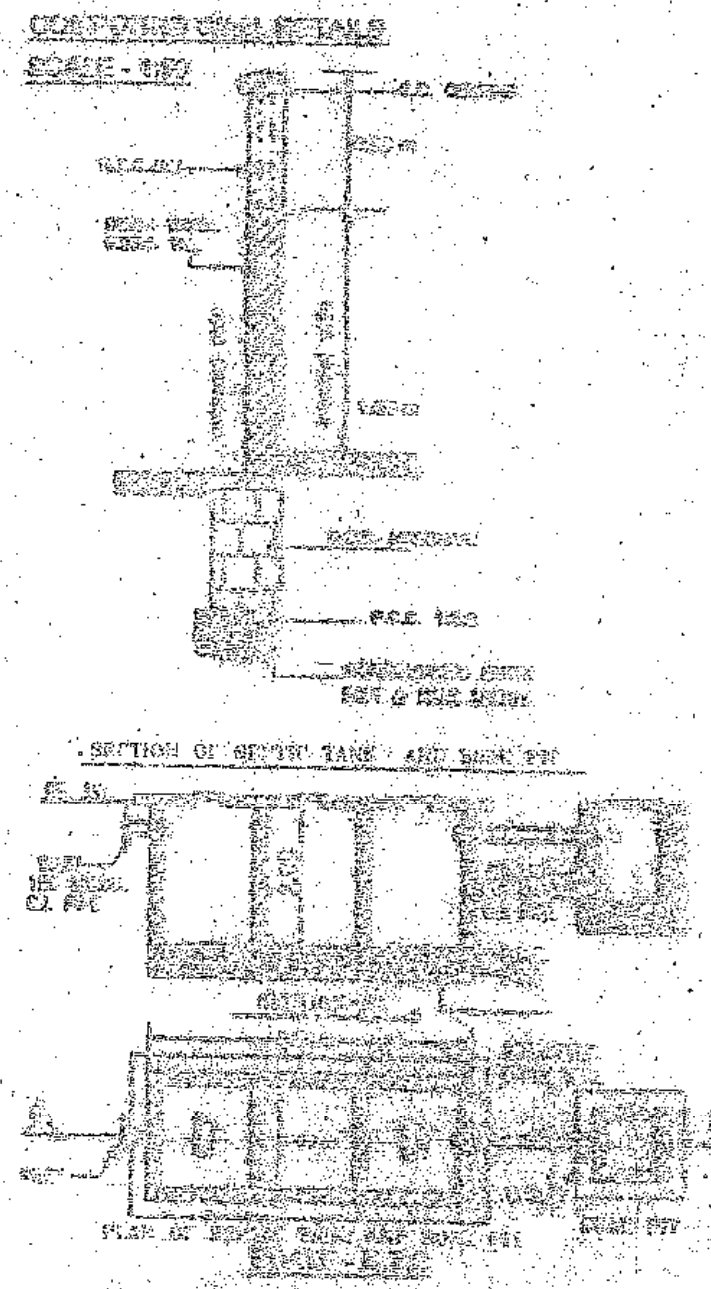
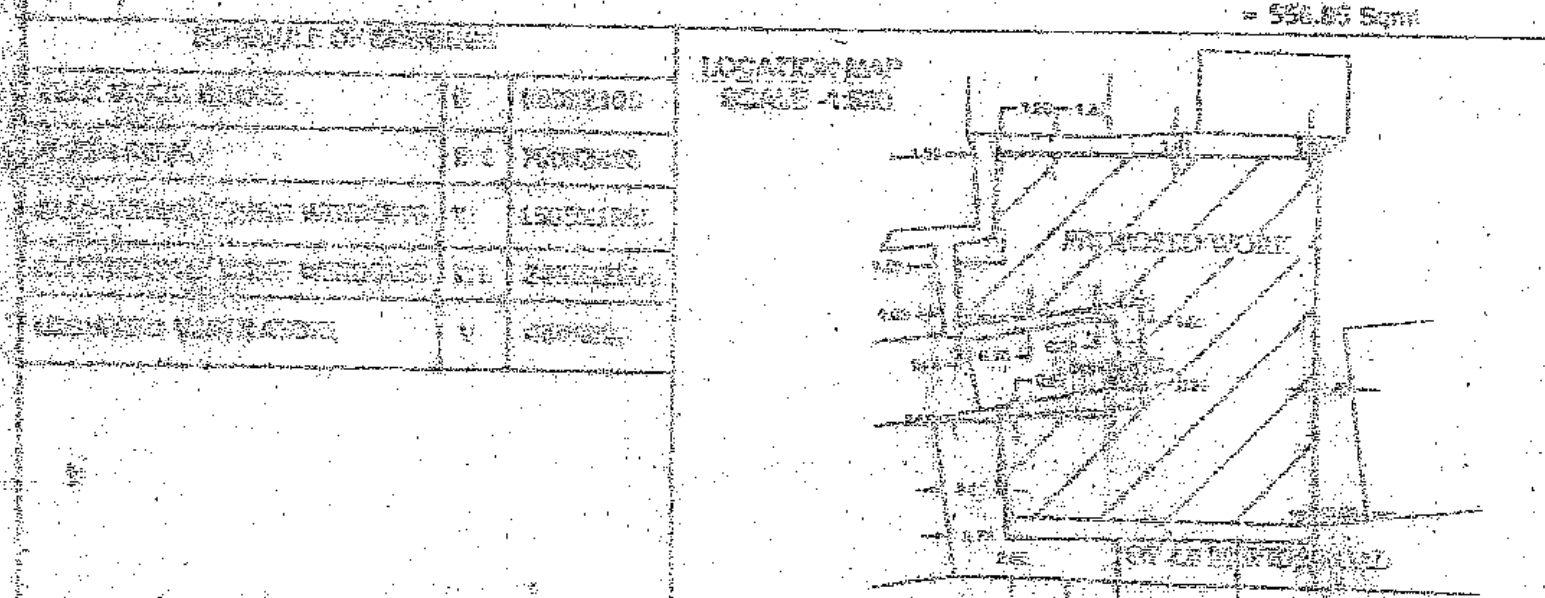

ARCHITECTS & PLANNERS:
KARLES PAMAR & ASSOCIATES
MARUTI SAGAR Co., Sec. 2, Sec. 16,
New Delhi, India

STAMP OF PLAN APPROVAL
MUNICIPAL CORPORATION
NEW DELHI

STAMP OF PLAN APPROVAL
MUNICIPAL CORPORATION
NEW DELHI

STAMP OF PLAN APPROVAL
MUNICIPAL CORPORATION
NEW DELHI