

SEAL OF APPROVAL

APPROVED SUBJECT TO THE CONDITION MENTIONED IN the office letter

No. CIDCO/BP-15523/FPQ(NM)2017/1974
Dated: 08-09-2017 16 SEP 2017

MPW 29/9/17

Sr.Planner/Asso.Planner(BP)
CIDCO of Maharashtra Ltd.
Raighad Bhavan, 4th Floor.
Plot No.4, Sector-11.
CBD-Belapur, Navi Mumbai.

BUILDING: B (1)

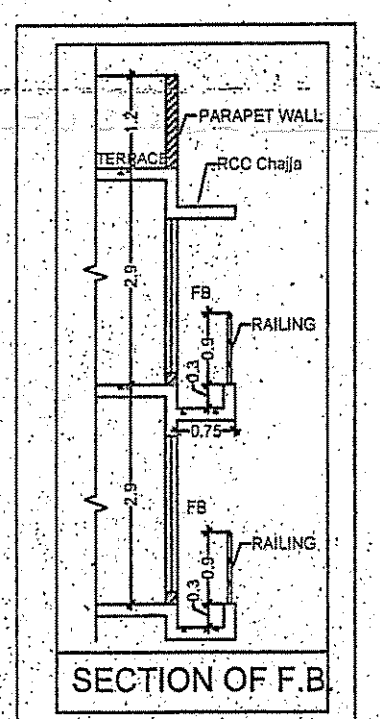
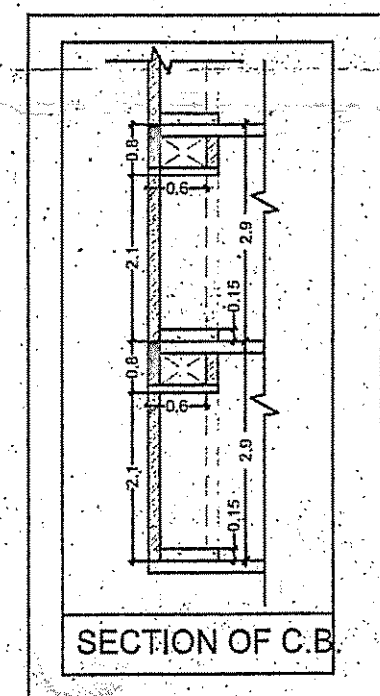
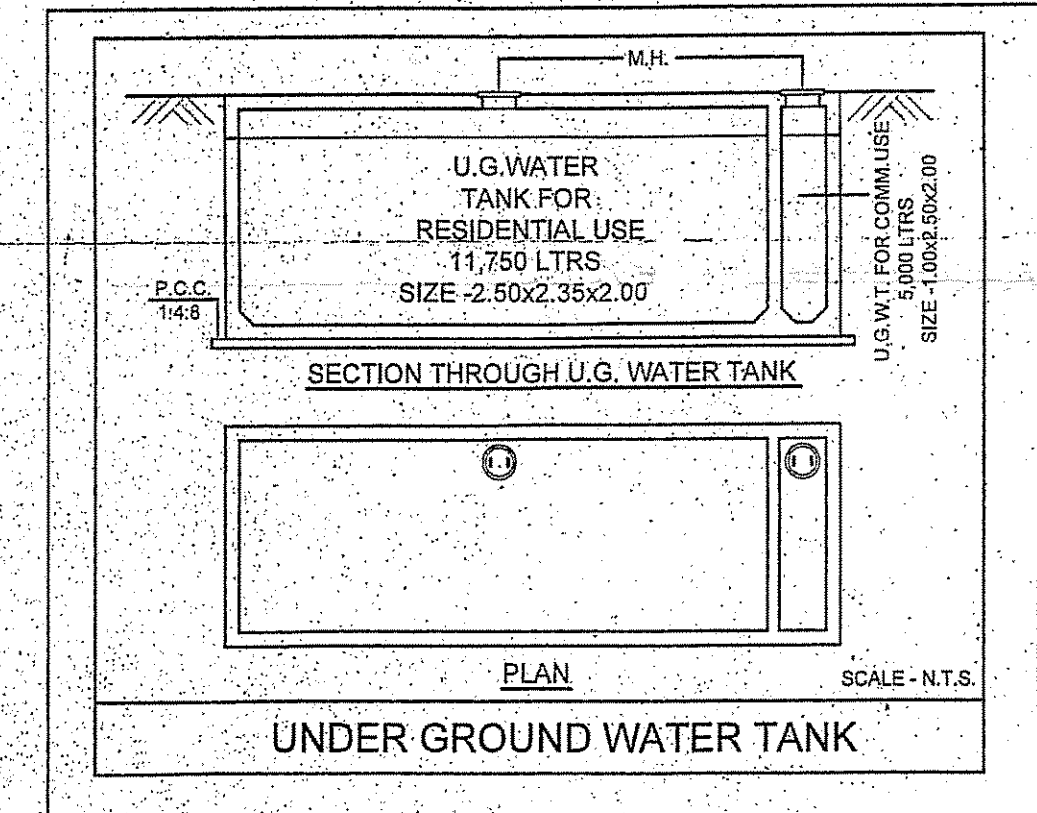
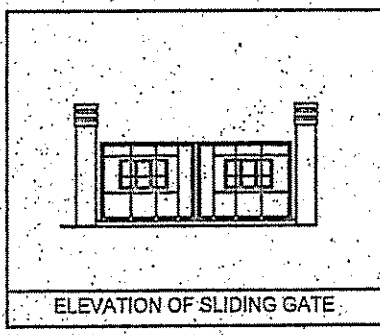
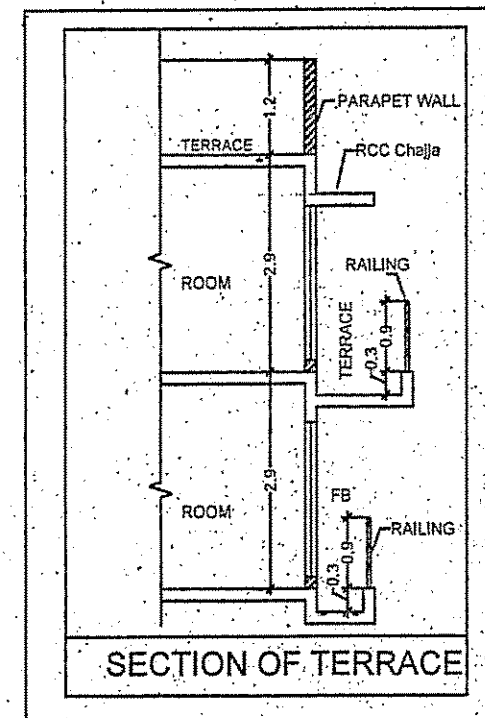
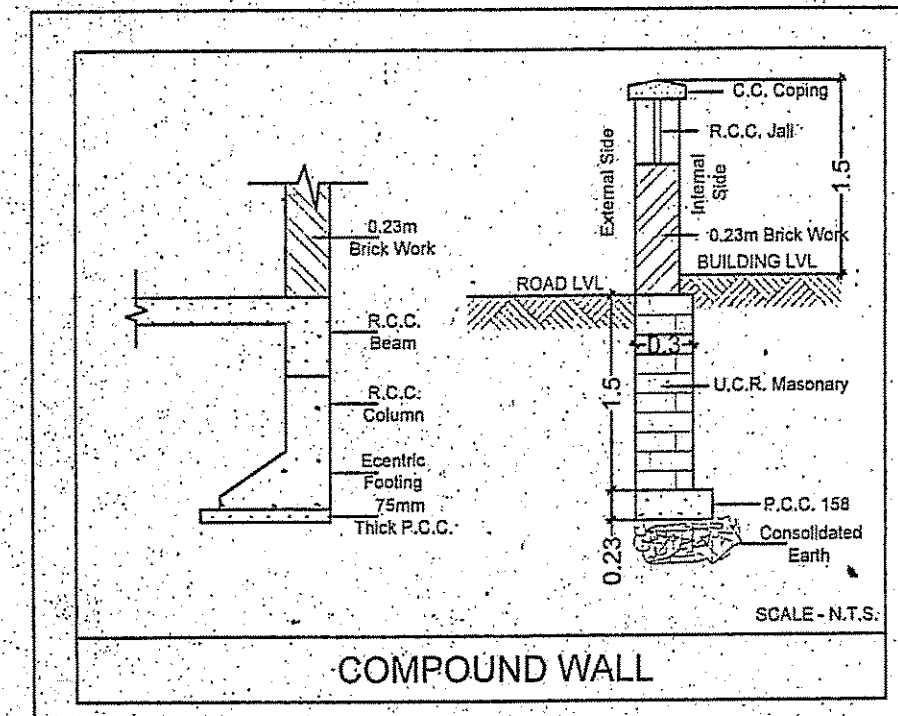

OWNER'S NAME
M/S. G.A. ENTERPRISES, THROUGH ITS PARTNERS, MRS. MAMTA N. GARG
AND M/S. SUREE ALPA ENTERPRISES, THROUGH ITS PARTNERS, M.
RAJENDRAJI BHANUSHALI & PARTNER

PROJECT INFORMATION
PLOT NO: 19A SECTOR NO: KHARGHAR (NEW)
NODE: Kharghar (New)

PROJECT TYPE: RESIDENTIAL

CONSULTANT NAME: ATUL PATEL ARCHITECTS

ATUL PATEL ARCHITECTS
For: ATUL PATEL ARCHITECTS

ATUL PATEL ARCHITECTS
101, Sector 11, CBD Belapur, Navi Mumbai - 400157
T: 022-27746441-42

JOB NO.: 149 **ORG. NO.:** 1 **SCALE:** 1:100 **DRAWN BY:** [Signature] **CHECKED BY:** [Signature]

INWARD NO.: CIDCO/BP-15523/FPQ(NM)2017/1974 **DATE:** 08-09-2017

KEY NO.: 5-8 **SHEET NO.:** 2/2